

D A T A M A P P I N G C O R N W A L L

FOREWORD

This book presents a synopsis of an extensive study of the spatial behaviour of Cornwall undertaken by the Manchester School of Architecture (MSA) Infrastructure Space research group, supported by the Satellite Applications Catapult in collaboration with the Cornwall and Isles of Scilly Local Enterprise Partnership, Cornwall Council and NHS. This work was developed under the SMART and Well programme coordinated by the South West Satellite Applications Centre of Excellence.

This research has two primary goals:

1. To explore and develop methodological approaches which reveal crosscutting insights into the operation and performance of space and place in Cornwall and its wider regions.
2. To use the findings of these spatial explorations to explore novel approaches to design which tackle multi-dimensional problems in relation to service and physical infrastructure.

Generated from a starting point that considers Cornwall as a contemporary urban space within a rural context, this work comprises exploratory mappings that compare and spatially represent publicly available, existing data sets to identify opportunities and challenges for the county. Distance and physical connectivity provide challenges within Cornwall, yet today's digital communication and applications technologies offer opportunities to reimagine how communities can thrive when supported within wider and more responsive real and virtual networks.

With an overarching goal to understand the context that supports healthcare in the UK, focussing on Cornwall as a place, this work considers existing and potential relationships between physical and digital infrastructures. It explores the potential of creating intertwined relationships between these infrastructures and the spaces they define and inhabit to elevate performance and enhance health provision in

the region. The research embeds architectural understanding of human interaction with place and space. This is developed through critically testing, intersecting, representing and refining findings produced by analysis of data sets, supported by targeted field visits within four key themes:

- Networks and Connectivity
- Demographics and Economy
- Energy and Power
- Health and Lifestyle

The summaries provided in this book are extracts from longer 'atlases' that set out to compare datasets that are often viewed in isolation of each other. This approach that has been developed at MSA to help provide a critical understanding of how citizens and organisations use space and perceive place. This insight supports the identification of potential areas for projects and aims to frame how architectural, spatial and urban design approaches can support improvements to infrastructural networks that are often literally or culturally invisible. This document provides a summary of this spatial investigation of Cornwall, conducted by a large team of academics, experts and postgraduate students between September 2016 and March 2017.

msa Manchester School of Architecture

 **Manchester Metropolitan University**

South West
Centre of Excellence in Satellite Applications

CATAPULT
Satellite Applications

FALMOUTH UNIVERSITY

CIOS LEP

ACKNOWLEDGEMENTS

MANCHESTER SCHOOL OF ARCHITECTURE

Prof . Tom Jefferies: Head of School
Dr. Laura Coucill: Senior Lecturer
Richard Morton : Associate Lecturer
Dr. Luca Csepely-Knorr: Senior Lecturer

SPECIALIST INPUT

Stephen Horscroft: Cornwall + Isles of
Scilly LEP / Cornwall Council, Economic
Planning and Strategy Officer

Anna Mankee-Williams: Strategic
Partnership Lead for Innovation and
Technology in Care Falmouth University

Cathrine Armour: Director, South
West Centre of Excellence in Satellite
Applications

MSA POSTGRADUATES

Health and Lifestyle

Leonie Millington
Enrica Stanzani
Rob Makey
Robin Morgan
Andrew Singer

Energy and Power

Connor Armitage
Thomas Fantom
Antoine Louchet
Evagelia Nella

Networks and Connectivity

Kotryna Dapsyte
Morgan Wild
Peter Bell
Stephen Morris
Clara Burel

Demographics and Economy

Alexander Gaul
Jack Hines
Andrew Scoles
Jonathon Heyes
Stella Charbit

COVER DESIGN + GRAPHIC SUPPORT

Diane Kwan
Sam Power
Simina Ionescu

CONTENTS

| | |
|--|-----------|
| DEMOGRAPHICS + ECONOMY | 8 |
| Themes Explored | 10 |
| Migration | 12 |
| Seasonality | 13 |
| Legacy + Deprivation | 14 |
| Urbanity | 15 |
| Second Homes | 16 |
| Affordability | 17 |
| Education | 18 |
| Economic Identity | 19 |
| Data + Higher Education | 20 |
| Digital Industries | 21 |
| Industry | 22 |
| Funding | 23 |
| NETWORKS + CONNECTIVITY | 25 |
| Network Overview | 26 |
| Congestion Change | 28 |
| Road Network Fragility | 30 |
| Public Transport | 32 |
| Car Ownership | 34 |
| Accessibility to Hospitals | 36 |
| Limitations to Industry | 38 |
| Global Fibre Connections | 40 |
| Broadband Speeds | 42 |
| LSOA and Limited Access | 44 |
| Cornwall Garden City | 46 |
| ENERGY + POWER | 49 |
| UK Energy Future | 50 |
| National Grid and Smart Cornwall | 51 |
| Energy Consumption in Cornwall | 55 |
| Footprint and Capacity in Cornwall | 56 |
| Domestic Footprint and Capacity | 57 |
| Energy production Potential | 58 |
| Fuel Poverty | 60 |
| Findings (and Solutions?) | 65 |
| HEALTH + LIFESTYLE | 66 |
| Health + Lifestyle | 67 |
| Network of Health | 70 |
| Sport Infrastructure + Obesity | 72 |
| Fast Food + Deprivation | 74 |
| Socio-economic Groups + Adult Obesity | 76 |
| Anti-depressants + Lower Socio-economic Groups | 78 |
| Anti-depressants + Population | 80 |
| Suicide Attempt Call-outs + Mental Health Services | 82 |
| Care Facilities | 84 |
| Care Standards | 86 |
| Healthcare Connectivity | 88 |
| Call-out Comparison | 90 |
| Ambulance Response Times | 92 |
| Mapping Seasonal Pressures | 94 |
| Tourist Related Pressures | 96 |
| Digital Health Care | 98 |
| Integrated Emergency Services | 99 |

DEMOGRAPHICS + ECONOMY

Themes Explored

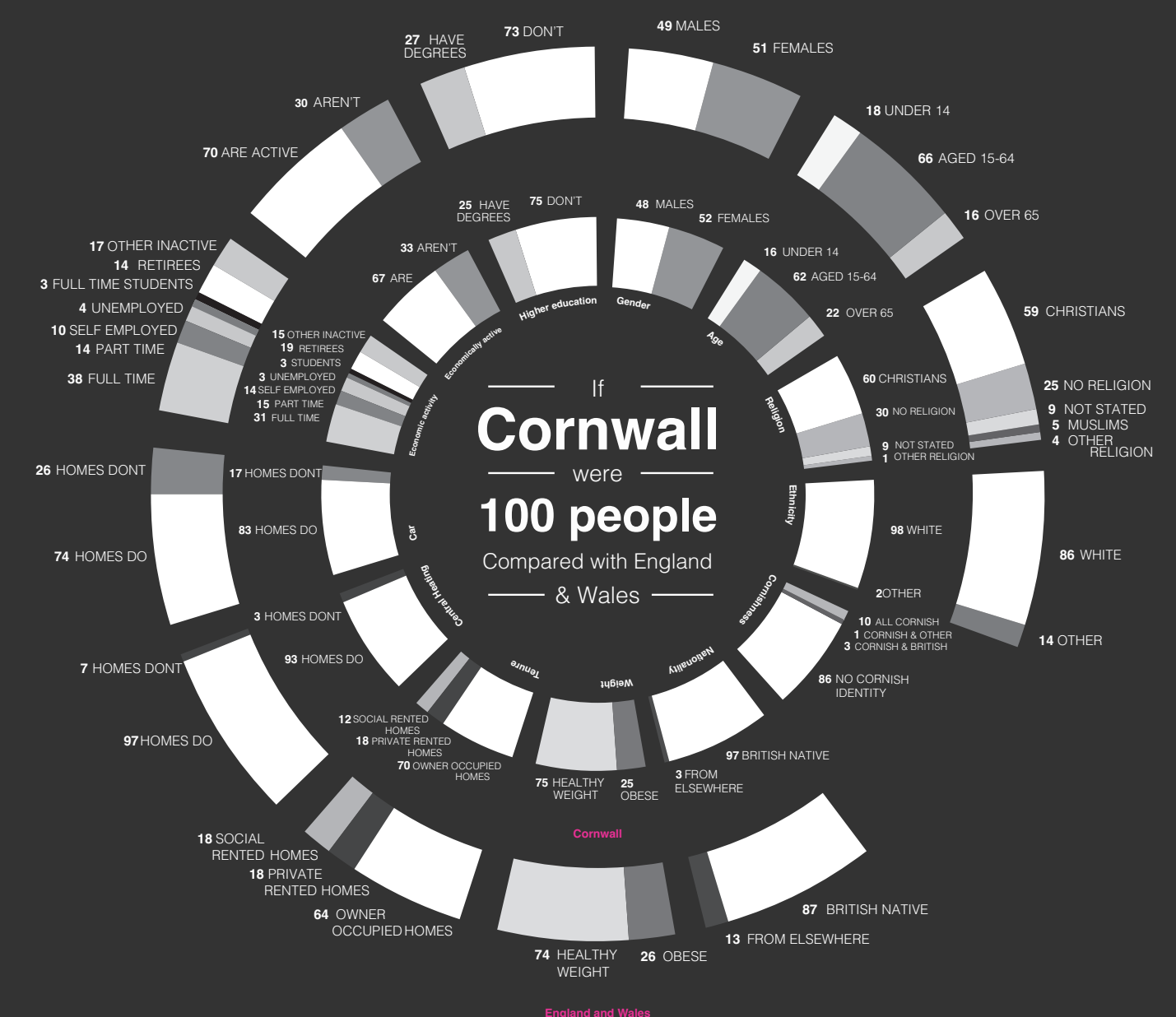
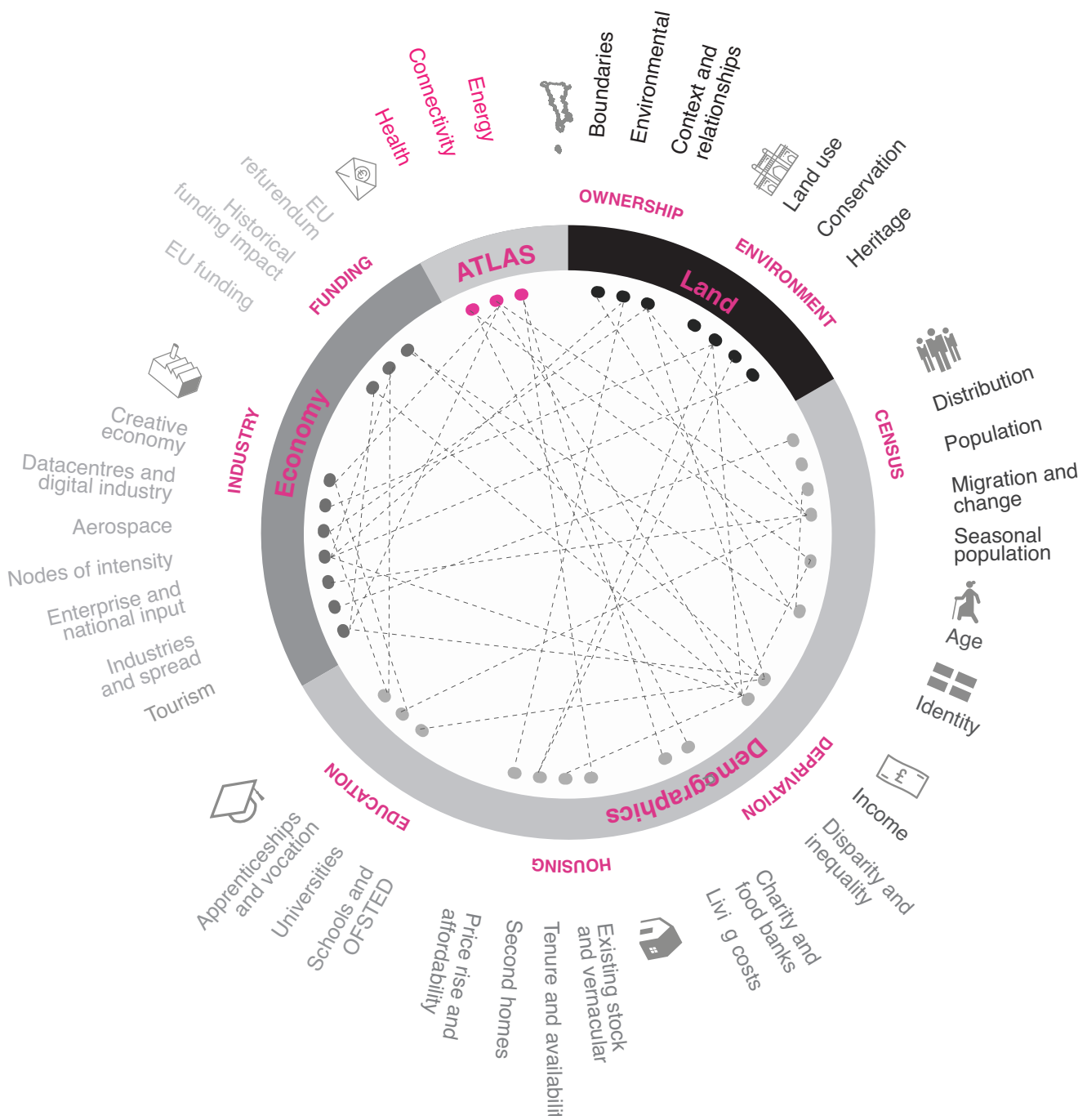

Migration

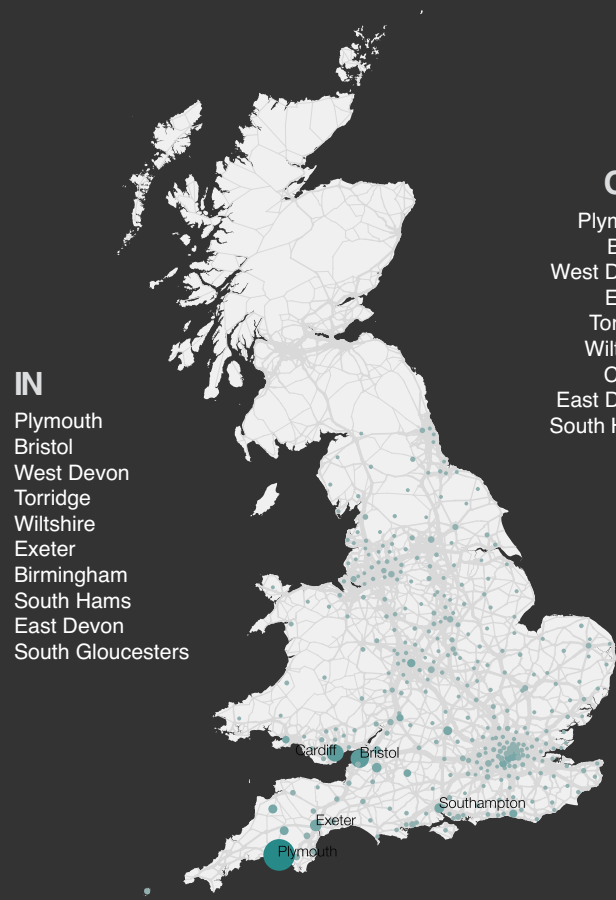

Ageing Population



31% is the predicted proportion of 65 and over in Cornwall by 2031

Source: Population and Household Change in Cornwall

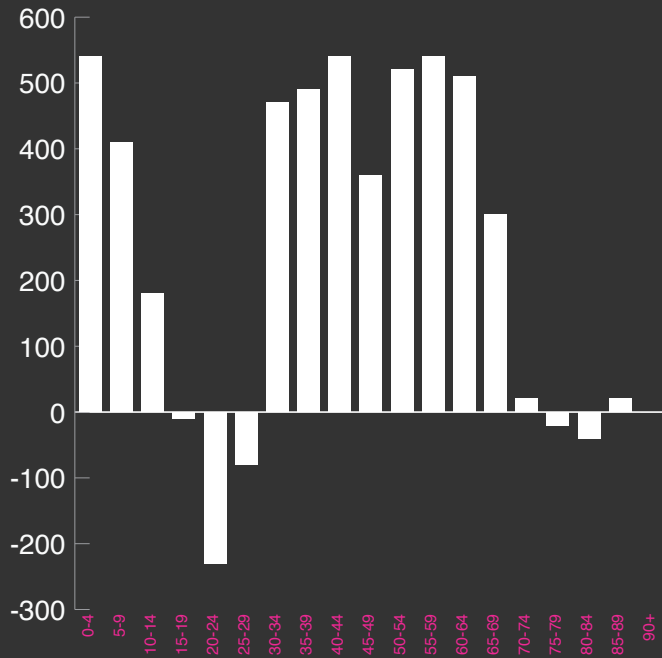

UNDER 15 15-25 25 AND OVER

Seasonality

£9 BILLION

Tourist earnings in Devon and Cornwall
Source: Western Morning News, 2012

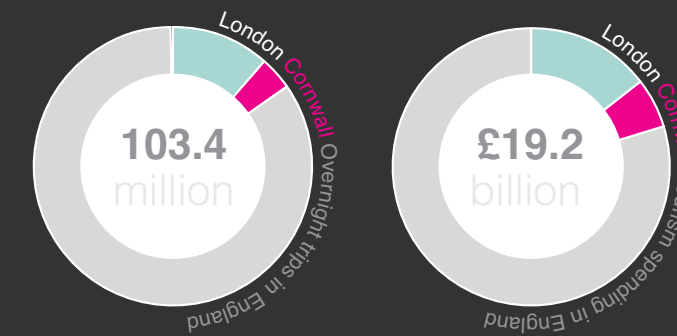

Three Year Averages By County (2012 to 2014)
Source: VisitBritain

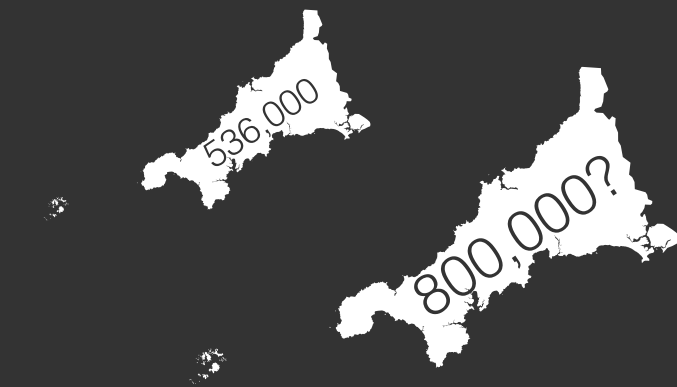

Using Visit Cornwall's average visitor numbers (and their average stay of 8.5 nights) we can estimate the peak summer population growth of between **225-300,000** people

Source: Visit Cornwall

Balancing the Winter Defi-

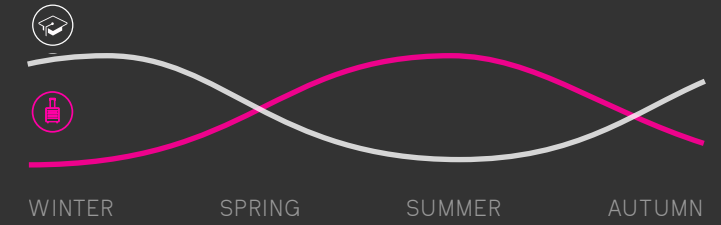

The flux in the student populations are opposite to those of tourist populations. Cornwall has an exceptional ability to host students, and yet it has one of the smallest student populations in the country.

6,750 **231,392**

Students Bedspaces
Source: Cornwall Council Accommodation Audit

Cornish Diaspora

There are an estimated **6 MILLION** Cornish names in existence around the world, (Parker, 2015)

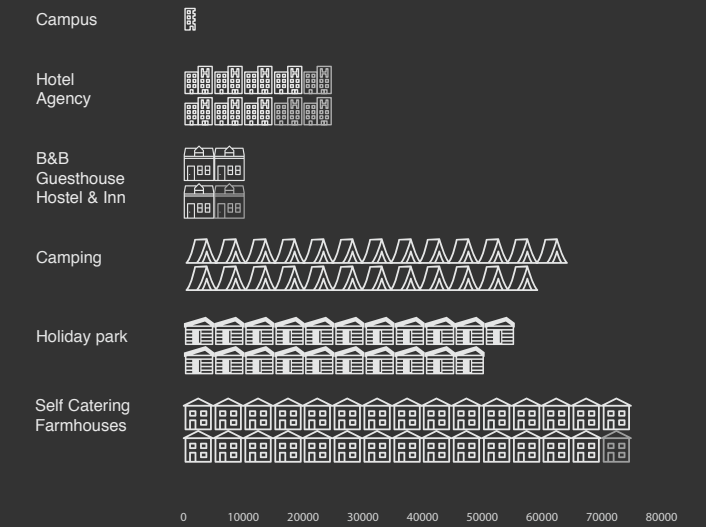
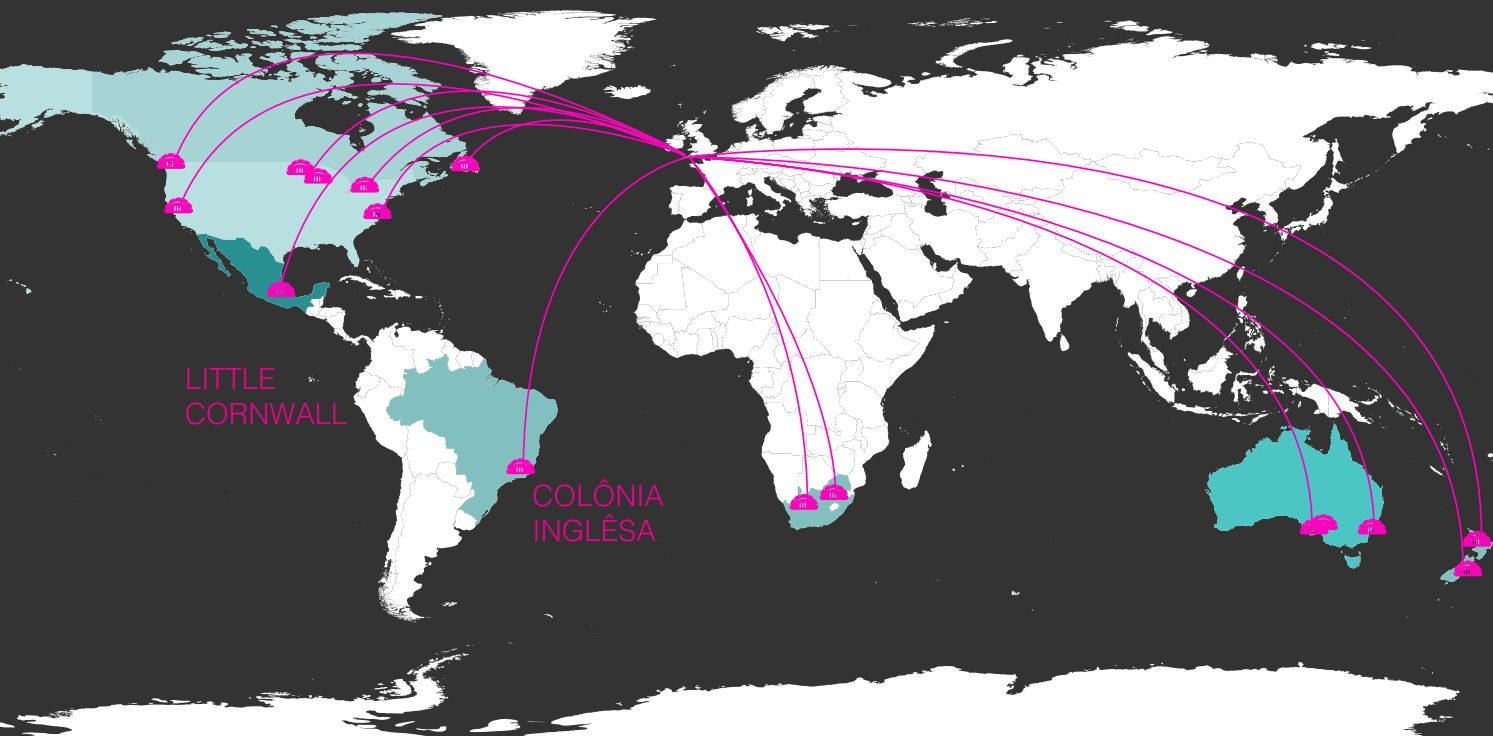

Fishing for Tourism?

Cornwall is renowned for its picturesque fishing towns, which draw in tourist revenue during high season but employment in the fishing industry appears to be low.

697KM long coastline

650 people work in fishing and aquaculture
Source: Census 2016

Legacy & Deprivation

Heritage Without Hindrance?

Do heritage sites stand in the way of new opportunities in Cornwall?

KEY

- World Heritage areas
(covering 8800 hectares)
- Natural England areas
Sites of Special Scientific interest
Area of Outstanding Natural Beauty (covering 96400 hectares)
- Employment deprivation
English Indices of Deprivation 2015
- Former mines
and Engine Houses

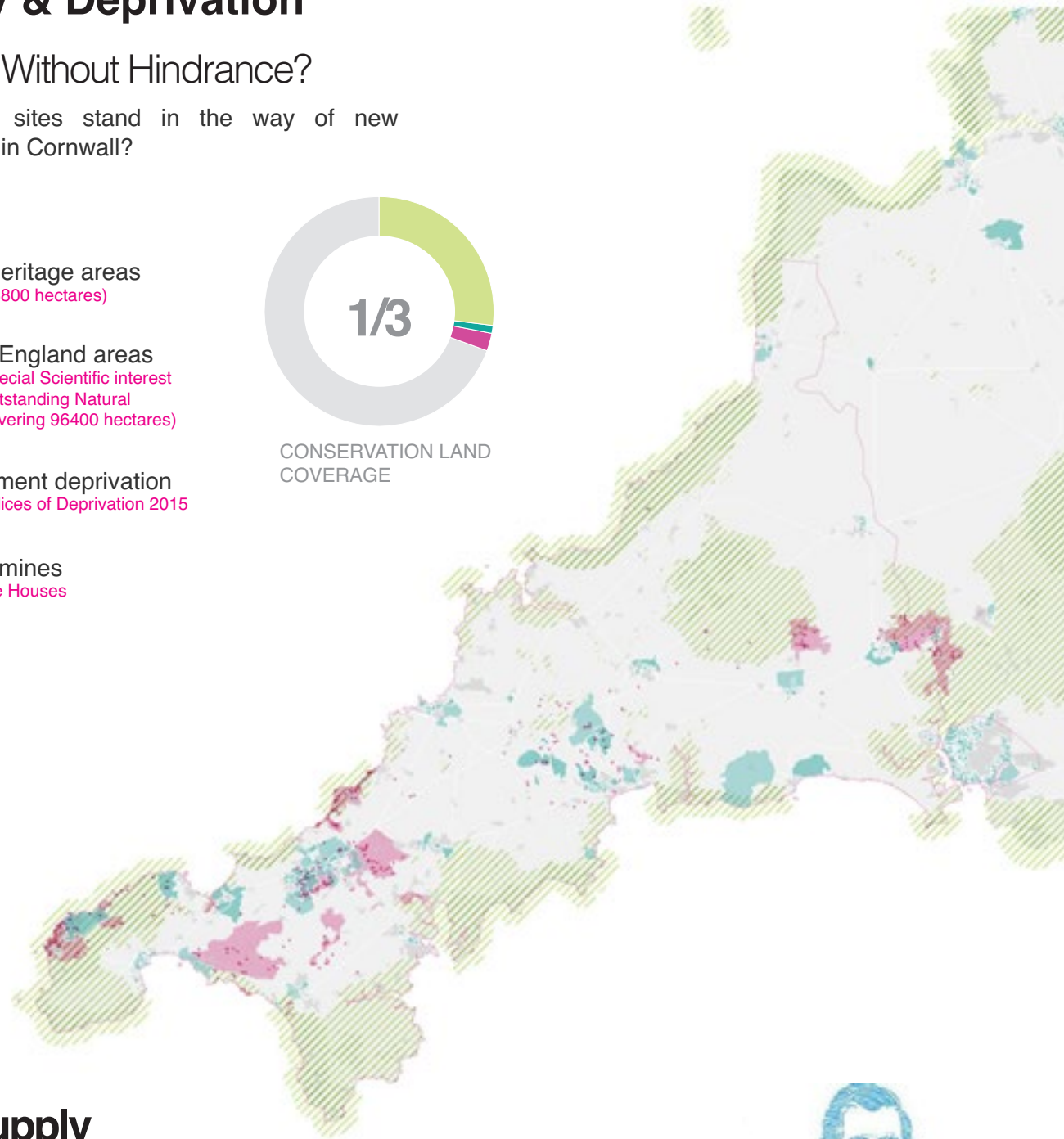
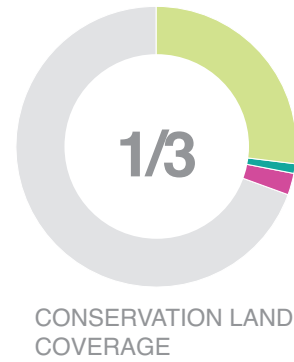

Land supply

Housing

High housing prices due to reduced land supply, and conservation areas in areas of significant housing deprivation.

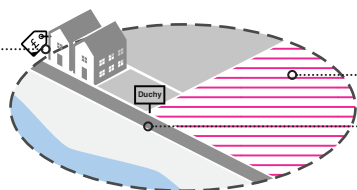

Industry

Poor industrial and employment opportunities in world heritage areas that cannot be comodified for tourism.

Stuart Dann, from Mining Eye, "compared the ground in the area to a huge piece of Swiss cheese, dotted with holes."

[JohnKirkhope, Pbs.plymouth.ac.uk](http://JohnKirkhope.Pbs.plymouth.ac.uk). Archived 28 March 2014.

Duchy

"A Mysterious, Arcane and Unique Corner of our Constitution"

There is a correlation between Duchy land ownership, as well as land limited by AONB status and housing deprivation.

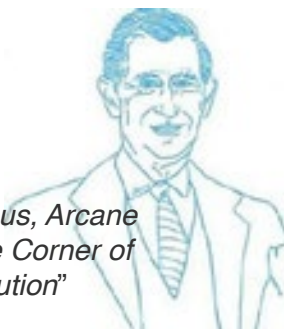

Urbanity

POPULATION DENSITY CARTOGRAM

Cornwall is one of England's most dispersed counties, however its distribution makes it a largely suburban/edgeland condition, with little truly rural space.

Cornwall's form and geological conditions coupled with connectivity issues create the perception of isolation and the retention of the Cornish national identity.

- Rural
 - Suburban
 - Urban
- National rural/urban classification

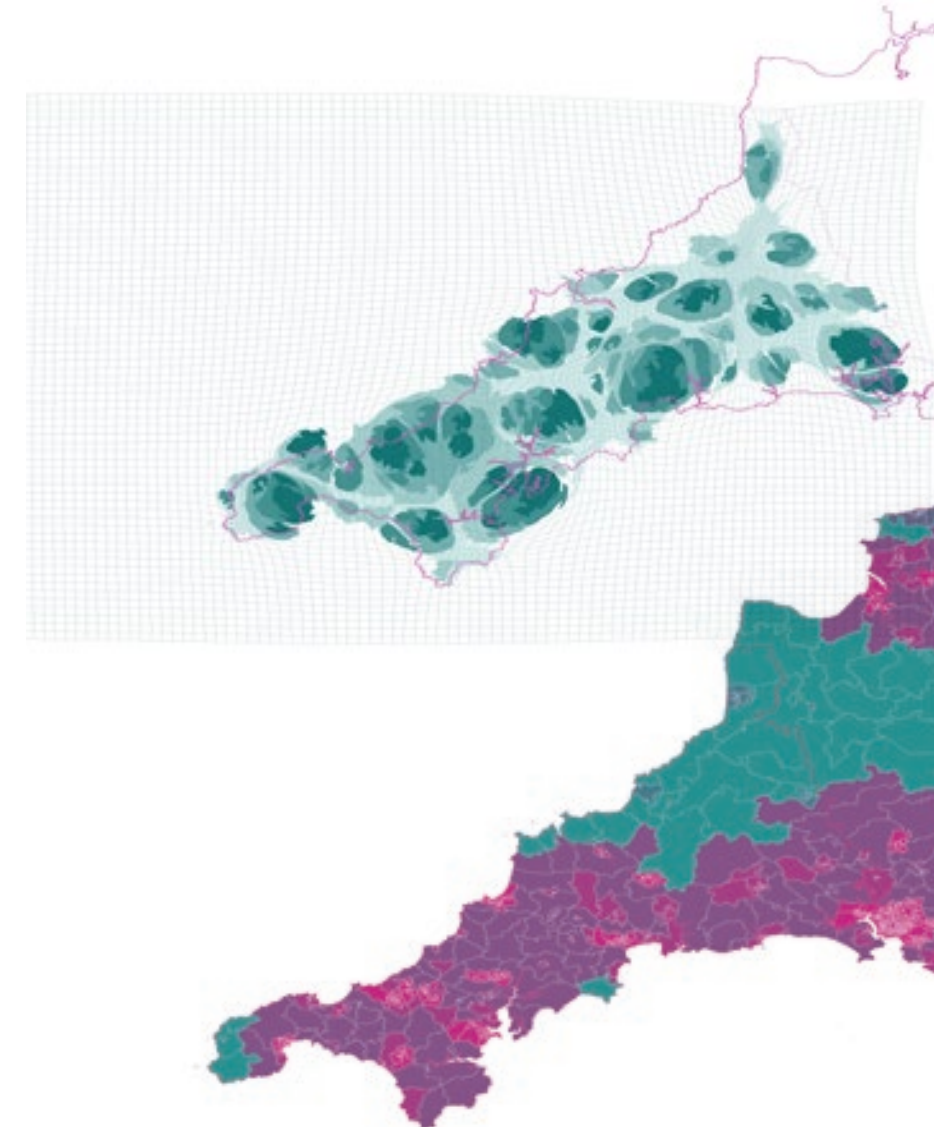

Plymouth

The population of Cornwall's 19 largest towns (including the City of Truro) is equivalent to the Plymouth Metropolitan area.

KEY

- 25401 Live in Cornwall & Work in Truro
- 9,780 Live in Cornwall & Work in Plymouth
- Towns by population
Census 2011

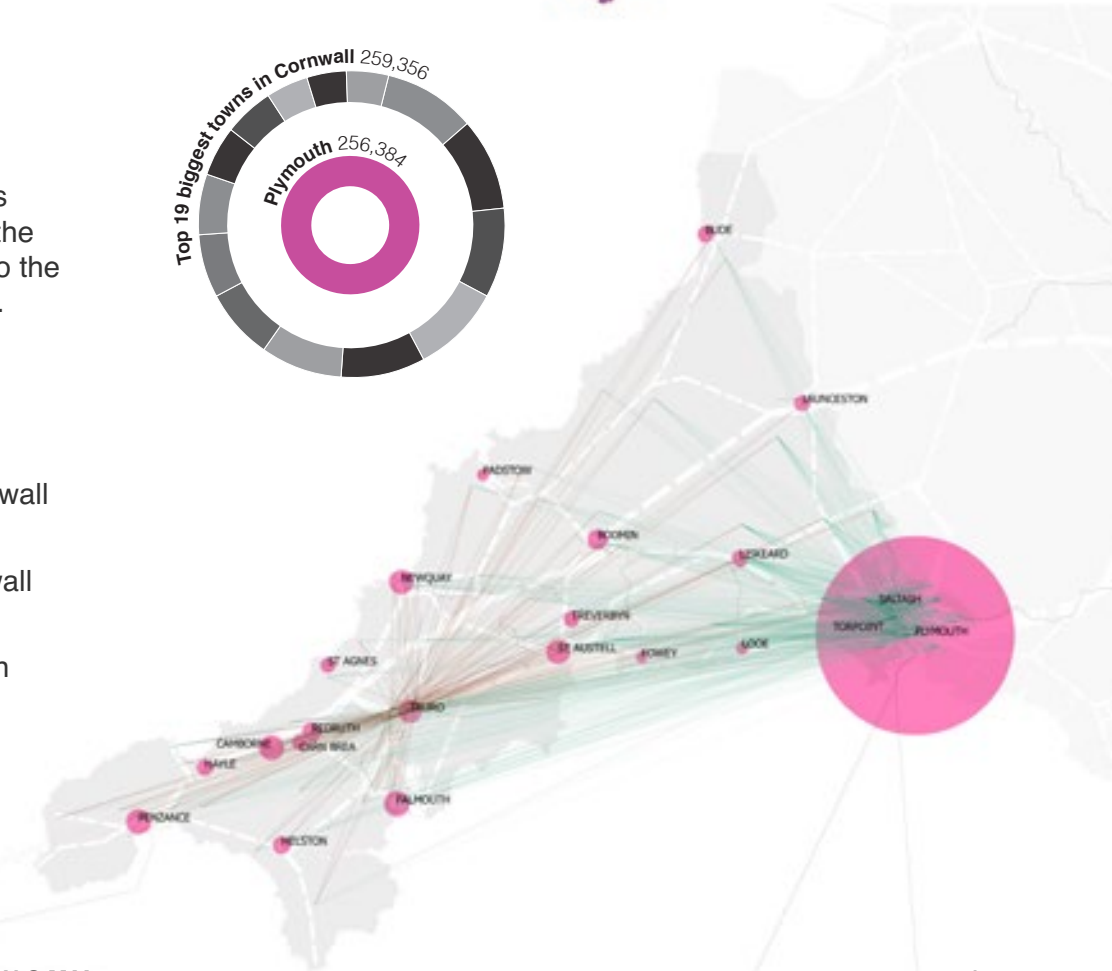
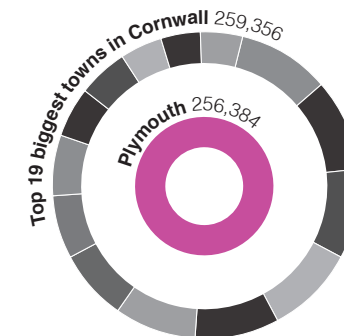

Second Homes

KEY

- Areas of Outstanding Natural Beauty
Natural England areas covering 96400 hectares in Cornwall
- Highest % of Second Homes
LSOAs where more than 15% of the properties are second homes

11.2% of Cornwall's housing stock are second homes. Cornwall has the second largest percentage of second homes after London, causing a strain on services and infrastructure. There is a clear correlation between the AONB and where the majority of second homes are located, this is mainly found on Cornwall's coasts. In contrast the lowest areas for second homes are located inland, away from the AONB.

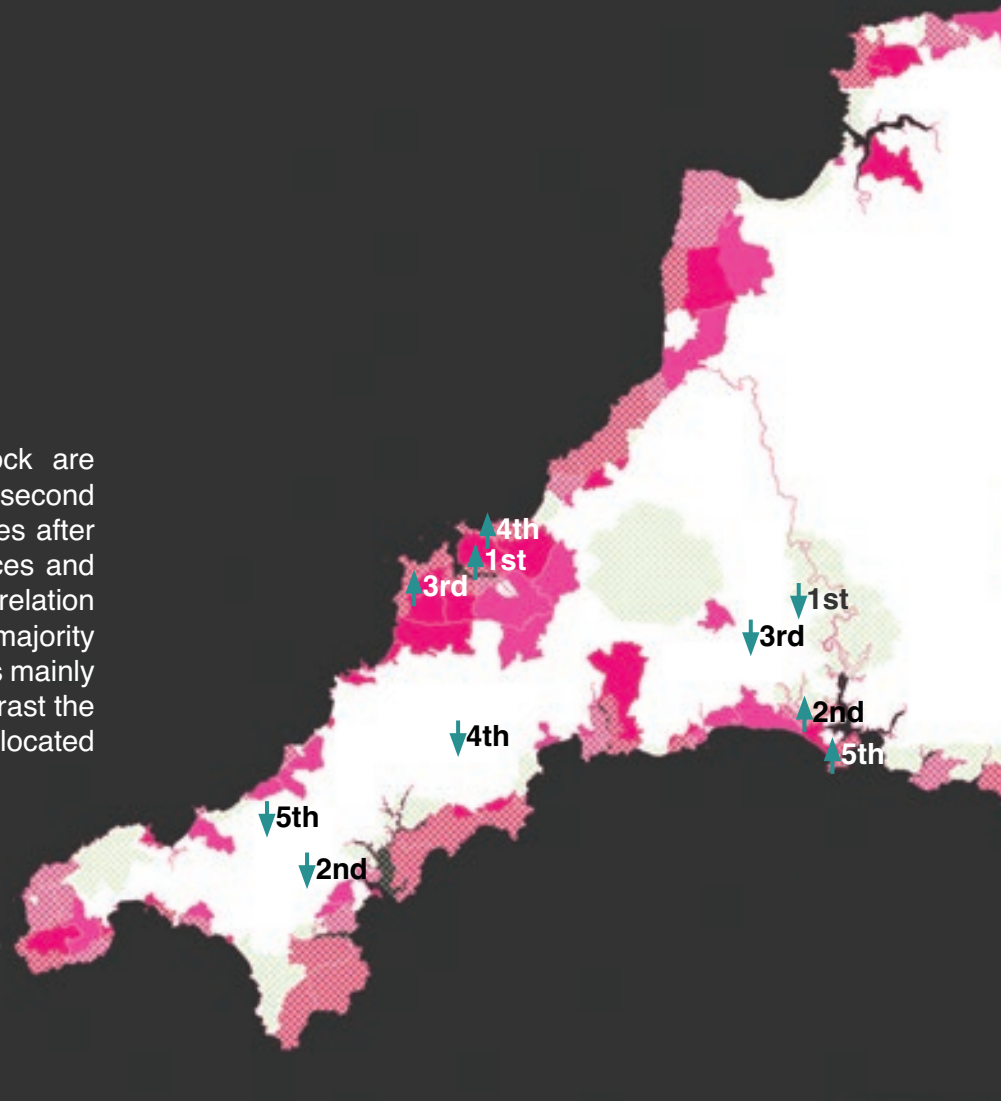

- Highest Median House Price
LSOAs where the median house price is greater than Cornwall's average of £245,907

The county experiences a disparity between high housing prices and low salaries compared to the national average. Mevagissey and St Austell have the lowest ratio of 10.6 with average property prices of around £184,000. Whilst Padstow has the highest ratio at 22, with an average house price of £381,812.

When mapping median house prices against second home ownership, there is a strong correlation which implies that second homes are driving up house prices. Compounded by low salaries, people are being priced out of certain areas.

House Prices

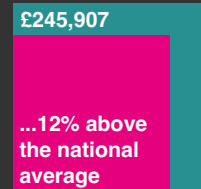

Income



10.6 Cornwall's ratio for house prices to wages.

7.8 England and Wales's ratio or house prices to wages.

Affordability

Cornwall's average house price has risen by 319% between 1995 and 2015, however areas which have a high proportion of second homes have seen the largest increase. The highest being in St Ives with a rise of 993%, seeing the average house price in certain areas of the town being pushed up to £627,000; 36 times the average income.

House Price Rise
Indication of how much the price of a house has risen between 1995 - 2015

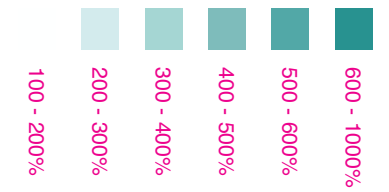

319%

...rise in average house prices between 1995-2015 in Cornwall.

6

...number of people from the top 10 of the Sunday Times Rich List with property in Rock.

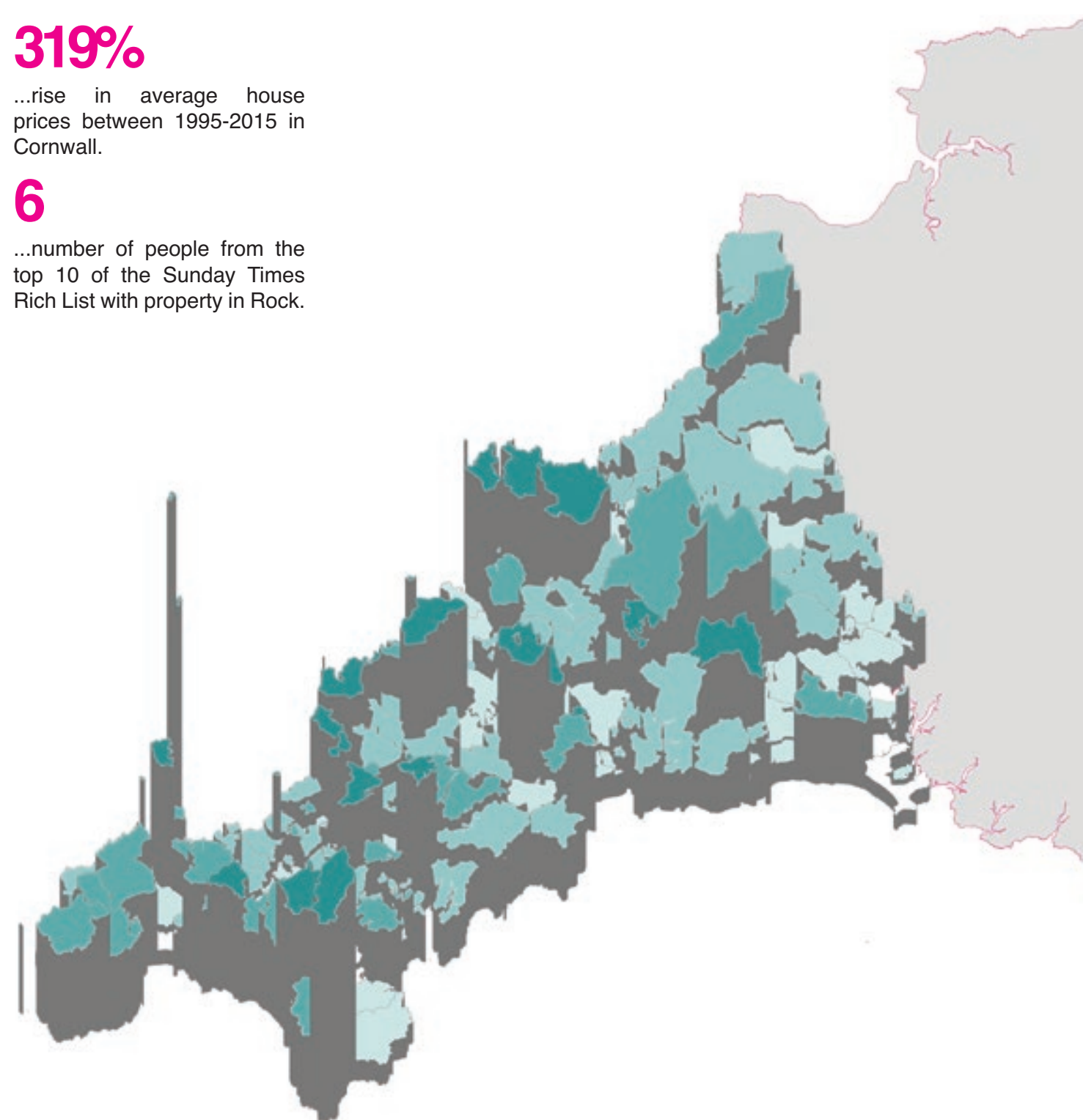

Education

KEY

- Students Achieving 5+ A* - C GCSE
34% - 73%. Primary schools and those missing data are represented in black.
(Performance Tables, 2015-2016)
- Education Deprivation
20%-40% worst (English IoD 2015)
- ▨ Population Aged 5-19
400-800/ 800-1200 of population aged 5-19 by LSOA.
(Census, 2011)

Cornwall's education system is performing well by UK standards however it is evident that higher education degree offerings and industry placements could better equip younger generation for more productive forms of industry. (Performance Tables, 2015-2016)

58.9%

Students achieved 5+ GCSEs at A*-C in Cornwall. 6.1% better than the England average at 52.8%.
(Department for Education, 2016)

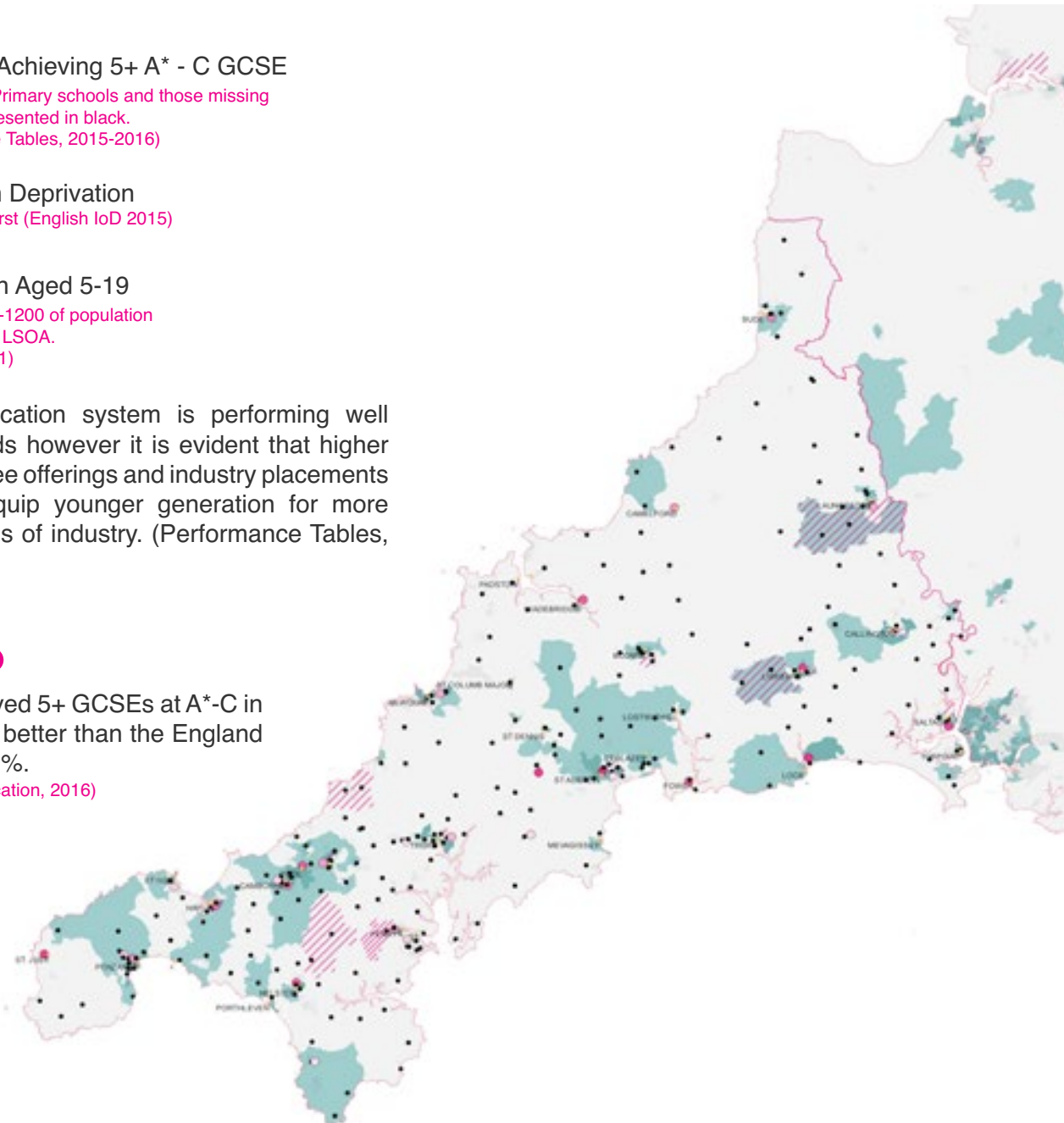

- Creative Arts, Design & Performing Arts, Media
- Sciences, Mathematics, IT & Computing
- Business & Management
- Engineering, Manufacturing & Technology

Higher Education

- Cornwall College - 1755 students
- Duchy College - 375 students
- Falmouth University - 4190 students
- Truro & Penwith College - 890 students
- Exeter & Falmouth's Penryn Campus - Not included in statistics

Economic Identity

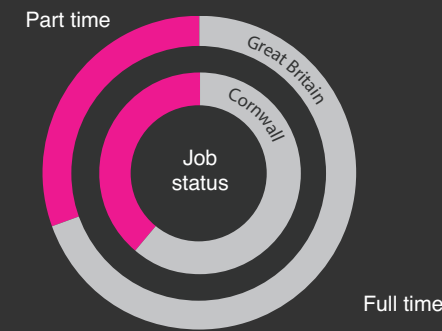

An overview of Cornwall's GVA (income) and employment gives an indication of the importance of certain industrial sectors to Cornwall's economy and working communities.

The perceived industrial heritage of Cornwall is one of agriculture, fishing and mining but in reality these industries only contribute a small percentage towards Cornwall's GVA and total employment.

Over the last two decades the UK has continued to develop a technical, finance and knowledge based economy, as manufacturing has declined, but Cornwall's economy has stagnated by comparison and has fallen behind in more profitable, economically sustainable industries.

Cornwall's economy has grown most in areas relating to tourism and the ageing population while the percentage GVA from Real Estate is still well above the National average - perhaps due to higher land prices.

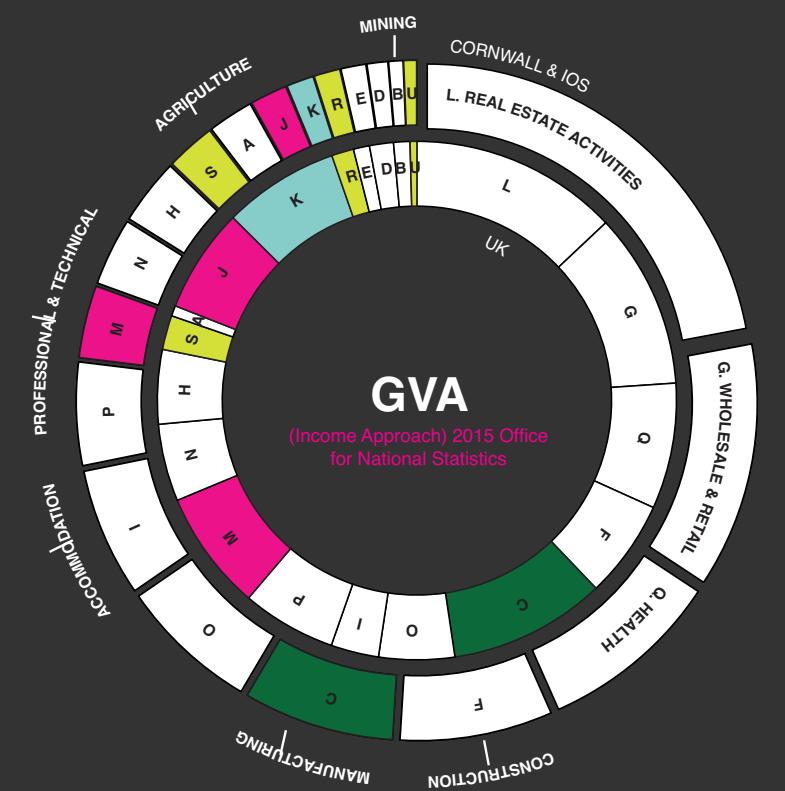
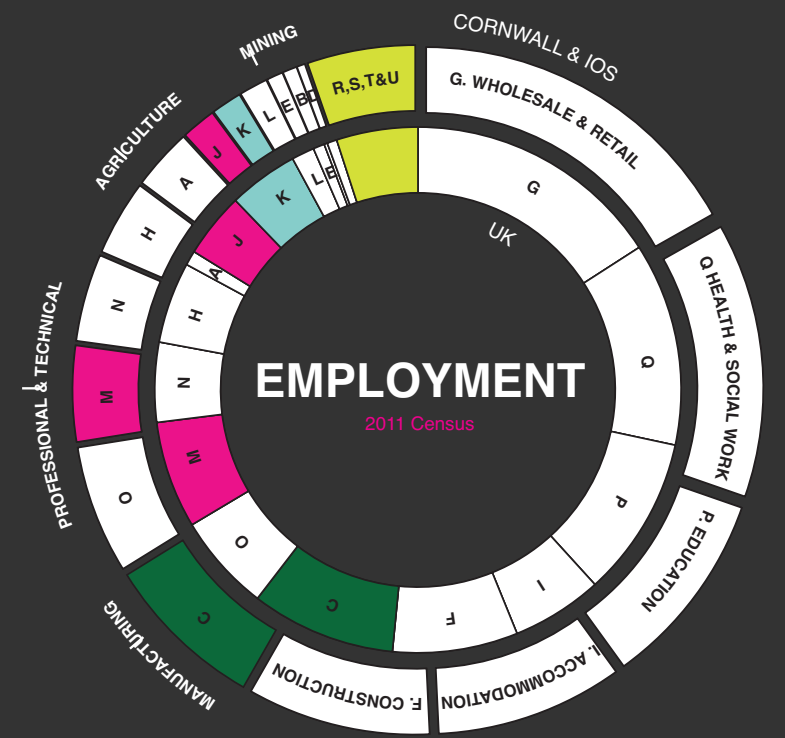

- A Agriculture, Forestry and Fishing
- B Mining and Quarrying
- C Manufacturing
- D Electricity, gas
- E Water supply, sewerage
- F Construction
- G Wholesale and retail trade
- H Transportation and storage
- I Accommodation and food
- J Information and communication
- K Financial and insurance activities
- L Real estate activities
- M Professional, scientific and technical
- N Administrative
- O Public administration and defence
- P Education
- Q Human health and social work
- R Arts, entertainment and rec
- S Other service activities
- T Activities of households as employers
- U Activities of extraterritorial organisations & bodies

Data + Education

Submarine Cables have nodes in Cornwall and SeaMeWe-3 cable enters Goonhilly, so why are there not more data centres?

Goonhilly is a suitable location for satellite communications due to its open horizon and stability from surface bedrock. Technological advancements have made the larger, higher quality 'Standard A' satellites less economically viable for communications. Instead, CUGA are conducting

further research with Aerials 1 + 3 and GES wish to support the European Space Agency with Aerial 6.

The site is ideal for hosting data as they can connect to the 10Gbps Jiscom network. They also have two inbound connections exceeding 100Gbps, meaning that interruptions are unlikely. Upgrades to the existing security would be required and so may improvements to the energy network. (Wilkes, 2017)



20%
Corporation Tax

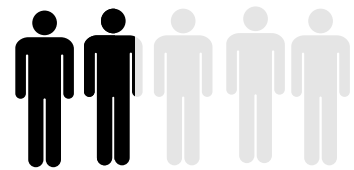

37% of people aged 25-64 in the UK are educated to tertiary level or above. (OECD, 2009.)

20%
Corporation Tax

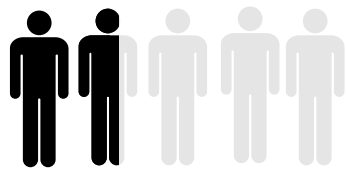

35.8% of people aged 25-64 in Cornwall are educated to tertiary level or above. (Guardian, 2009.)

Cornwall has the potential to be energy self-sufficient through the use of renewables. However, the current grid cannot support a greater load.

Direct data links to Mainland Europe.

Environmental technologies Enterprise Zone.

100% Business Rate reduction on fibre infrastructure for the next 5 years.

£23bn National Investment fund.

12.5%
Corporation Tax



22% of people aged 25-64 in Ireland are educated to tertiary level or above. (OECD, 2009.)

Ireland may be subject to a 20% electricity deficit once the UK leaves the EU.

No direct data link to Mainland Europe. A link to France is under consideration as a part of EU's long term strategy. This will require significant capital and time.

'IEA considers Ireland as a world leader in the development of smart grids.'

\$4bn+ data centre capital invested into Ireland since 2008.

Data Protection legislation in Ireland is one of the most advanced in Europe.

Digital Industries



"A rural location has traditionally been seen as a weakness. Cornwall is dissolving that urban myth, driven by superfast connectivity, a pipeline for delivering tech skills and a strong collaborative community." (Tech City; Nesta, 2016)

Why Cornwall?

Access to commercial property
Access to local networks
Access to business support

Improvements to be made

Greater supply of talent
Greater sector awareness
Greater access to finance

Truro, Redruth & Camborne

1,380 Digital tech economy jobs
162 creative businesses
6.2% of total businesses

17% Digital density
Employs 1259 people
7.4% of total employment

£31m Digital GVA
9.7% of total GVA

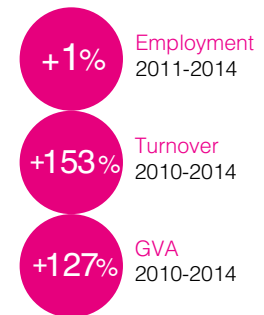

Internet speed
Average of the broadband coverage in the area's postcodes - Ofcom, 2015

Digital technology business
Tech City; Nesta 2016

Internet speed
41-82/ 103 - 204Mbps respectively. Based on speed tests by LSOA - thinkbroadband 2016

Income, employment & education deprivation
20%/ 20-40% worst performing areas - English Indices of Deprivation 2015

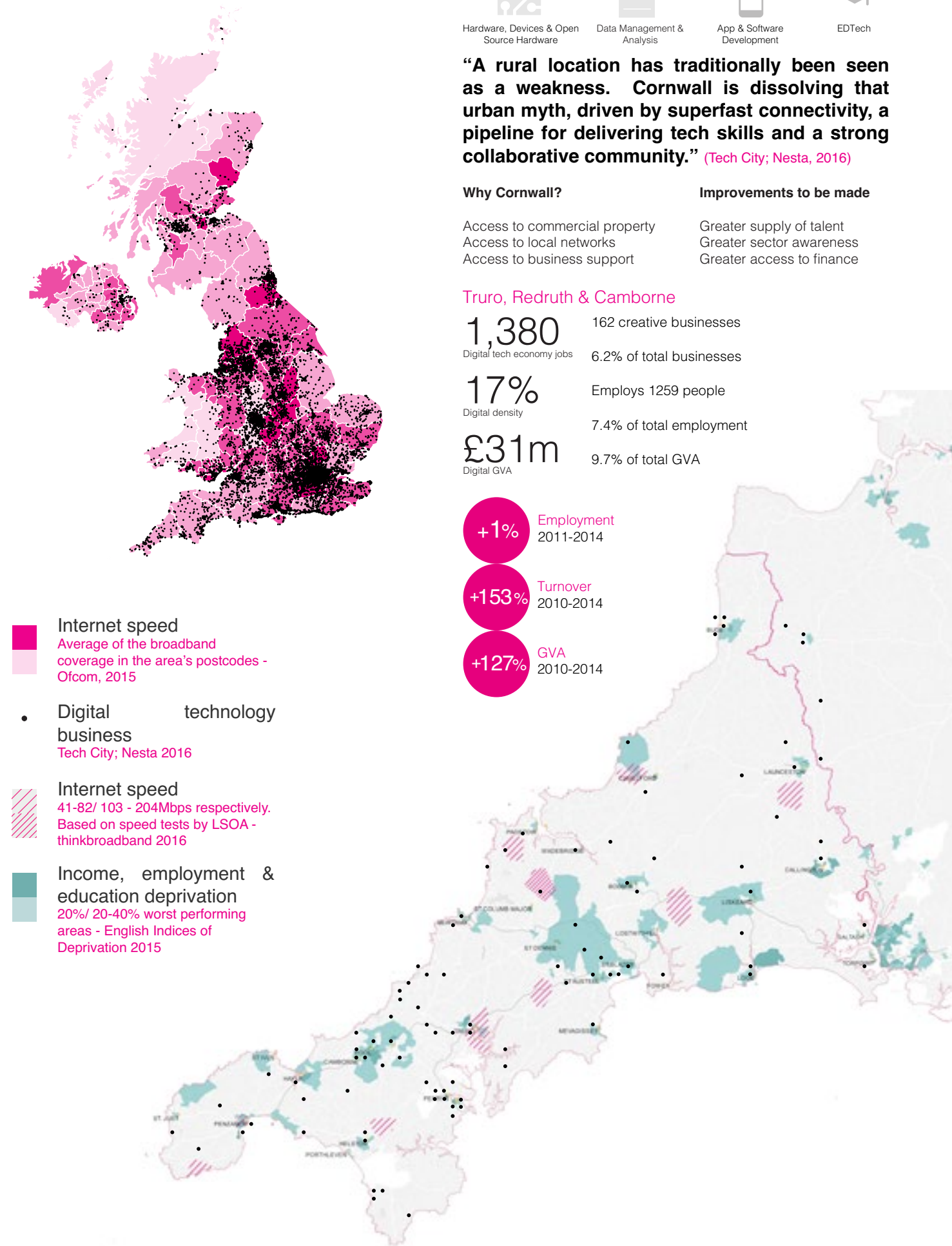

Industry

KEY

Deprivation
20% worst performing areas in terms of Income and Employment

Business
Mining or Quarrying (Companies House 2016)

% Employed
in Mining or Quarrying within LSOA (Census 2011)

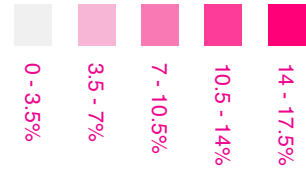

90% **\$100M**

of all identified mineral species are located on Kernow; **0.62%** of the planet's surface. (Golden Tree, 2016)

potential investment at South Crofty

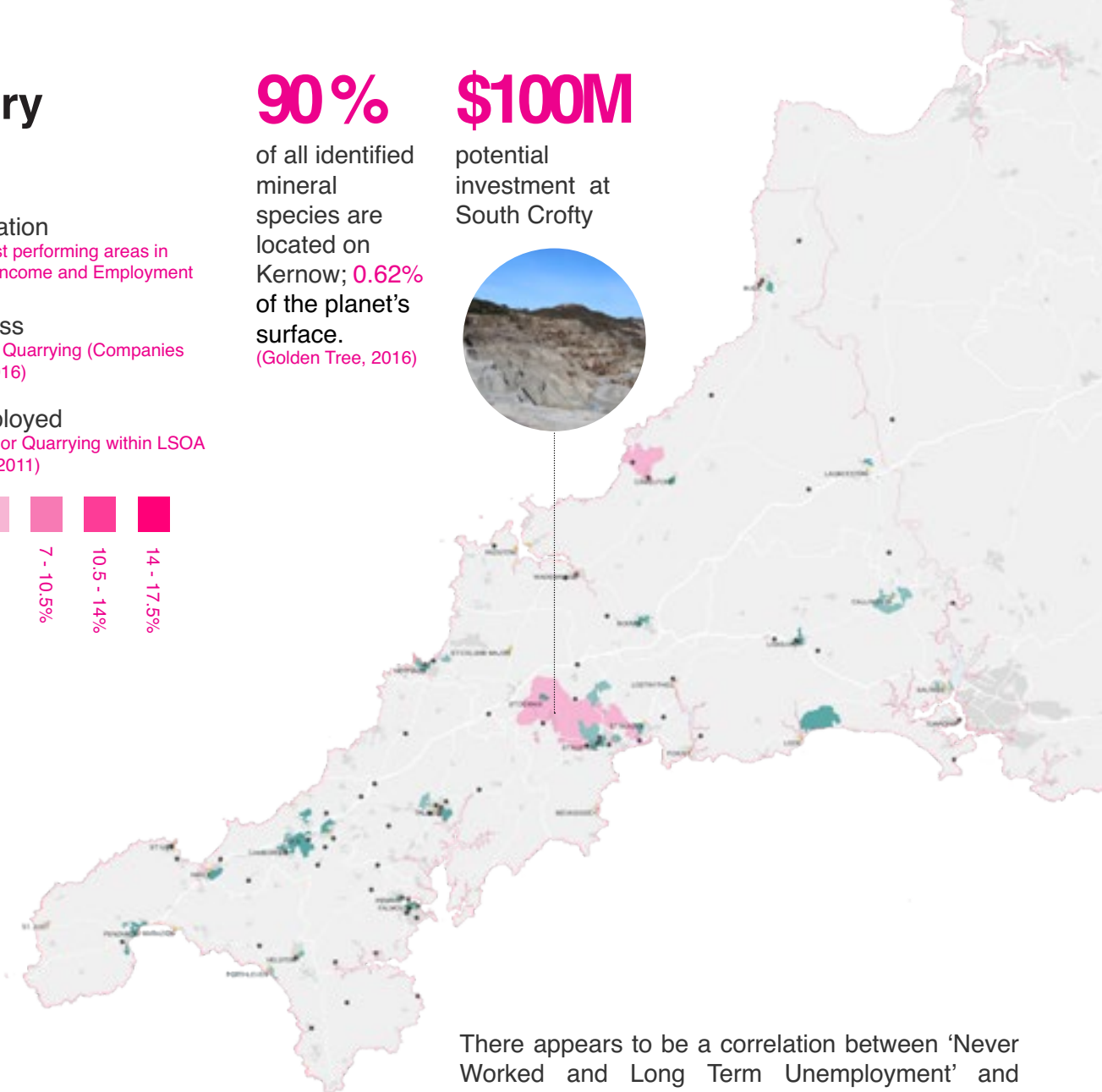
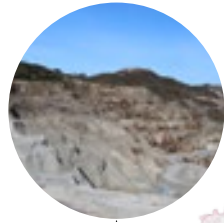

There appears to be a correlation between 'Never Worked and Long Term Unemployment' and education deprivation. This remains a challenge for former mining towns.

Canadian company Strongbow Exploration Inc. acquired the rights to South Crofty mine until 2071. However before it can become operational, approval is need to treat a million gallons of contaminated flood water at a local sewage plant before pumping it into the sea.

The acquisition follows the success of other UK mines such as Drakelands tungsten and tin mine opened in 2015 in Devon which provides 3.5% of global tungsten demand. (Resource Capital Funds, 2015)

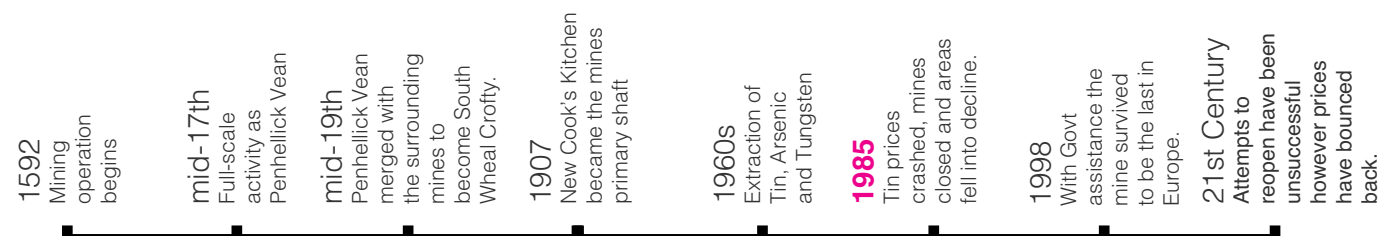
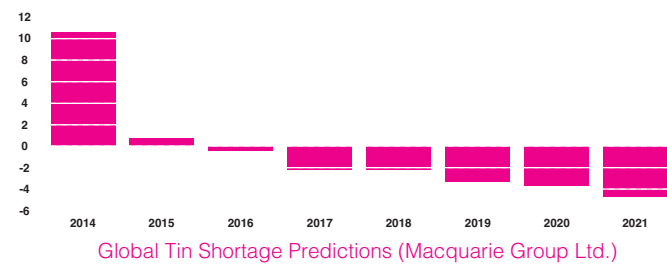

Funding

Cornwall received more EU funding than anywhere else in the UK over the last two decades. Cornwall voted to leave the European Union with a higher percentage of 'leave' votes than the UK average.

The 'remain' vote in Truro/ Falmouth correspond with EU funded success schemes that have had a positive impact on the local communities.

However, the votes to leave in Camborne and Redruth suggest that investment in high value sectors has not filtered down to the vulnerable communities and the demographic in these areas might require a different approach. The strong leave vote in St Austell and St Dennis support the hypothesis that these deprived areas have been forgotten.

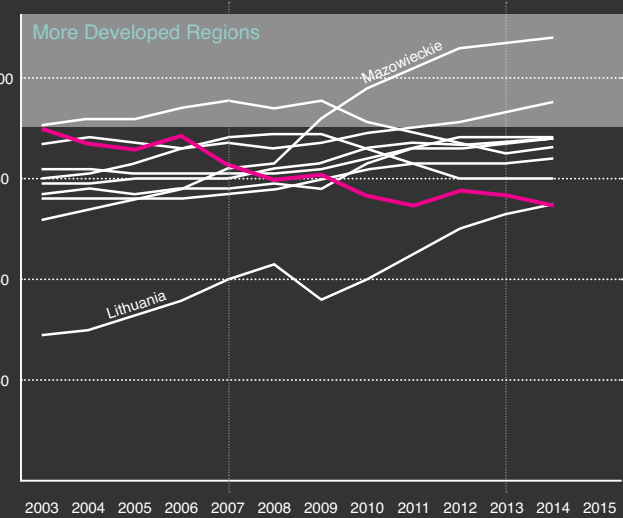

Regional GDP (PPS per inhabitant % EU) (Cornwall V Growth Regions)

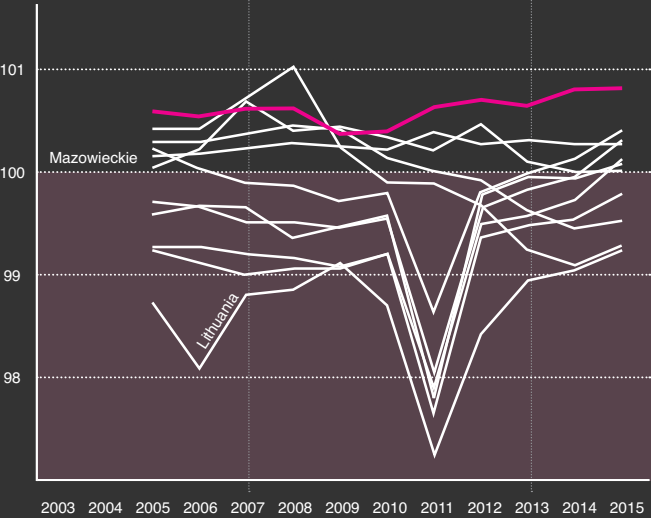

Regional Population Change (Cornwall V Growth Regions)







Cornwall currently ranks alongside Lithuania with some of Europe's poorest regions. While Cornwall's economy has continued to lose ground on the rest of the EU, other 'less developed' regions in eastern Germany, eastern Europe and Spain have improved during the last batch of Structural Funding. While these regions have improved their

GDP per capita they have all experienced negative or low population growth. These areas form a precedent for other low growth regions through: sustained growth of metropolitan areas; holistic plans for education and industry; and reformed economic identities that do not depend on tourism.

NETWORKS + CONNECTIVITY

Network Overview





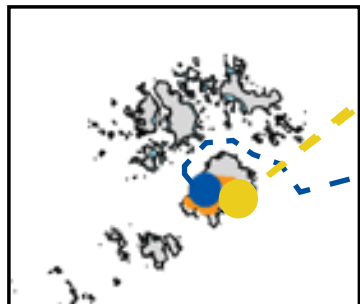
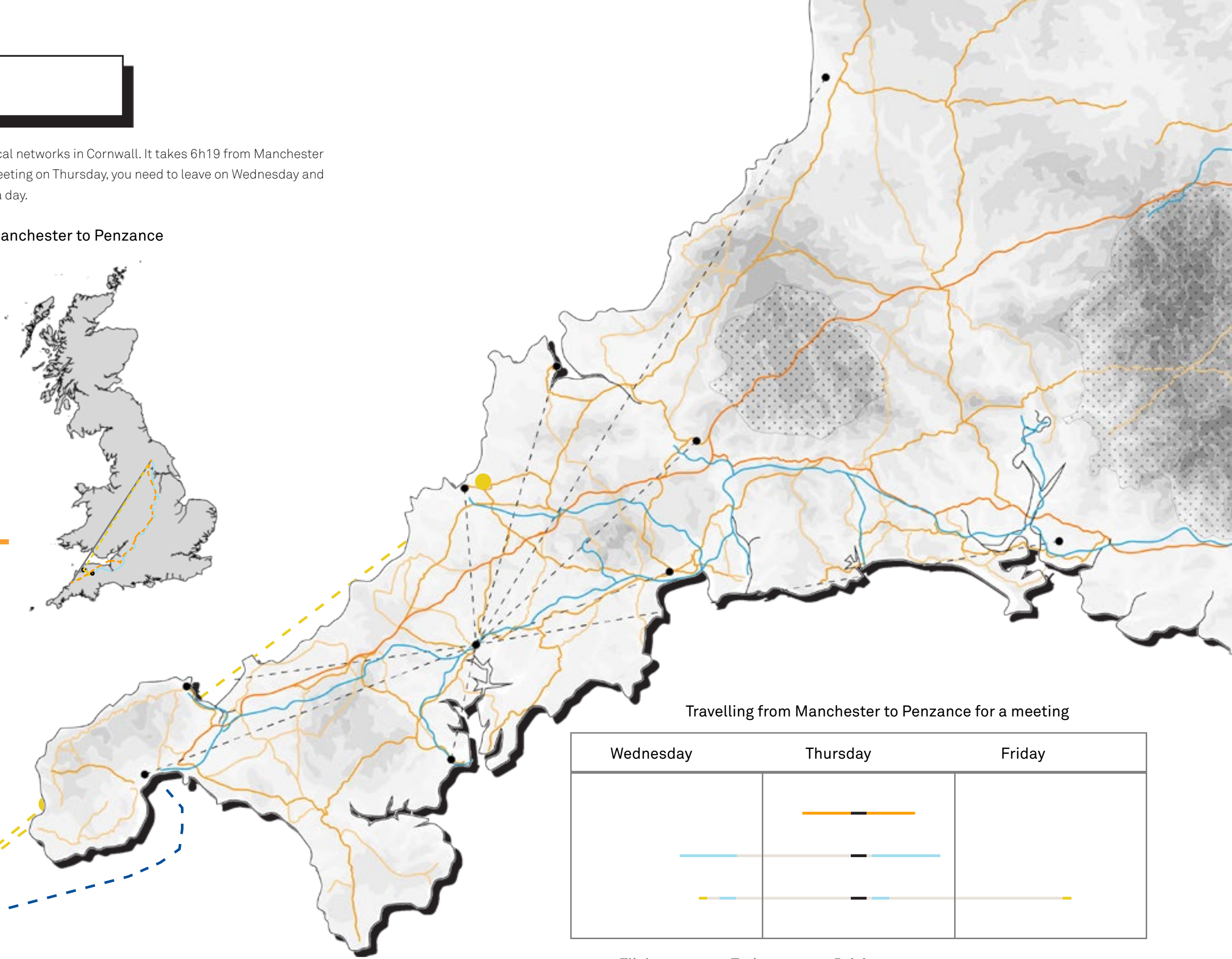
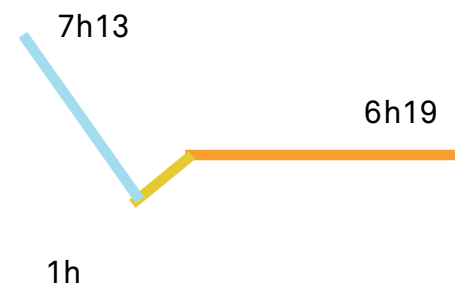

This map provides an overview of the physical networks in Cornwall. It takes 6h19 from Manchester to Truro. Due to flight times, if you have a meeting on Thursday, you need to leave on Wednesday and cannot until Friday as there is only 1 flight a day.

-  Linear routes
-  Flight paths
-  Train lines
-  Ferry routes
-  Roads
-  National park

Manchester to Penzance



Travelling from Manchester to Penzance for a meeting

| Wednesday | Thursday | Friday |
|---|---|---|
| |  | |
|  |  | |
|  |  |  |

-  Flight
-  Train
-  Driving
-  Waiting
-  Meeting

Congestion Change

Primary annual average daily traffic flow

High season average traffic

Low season average traffic

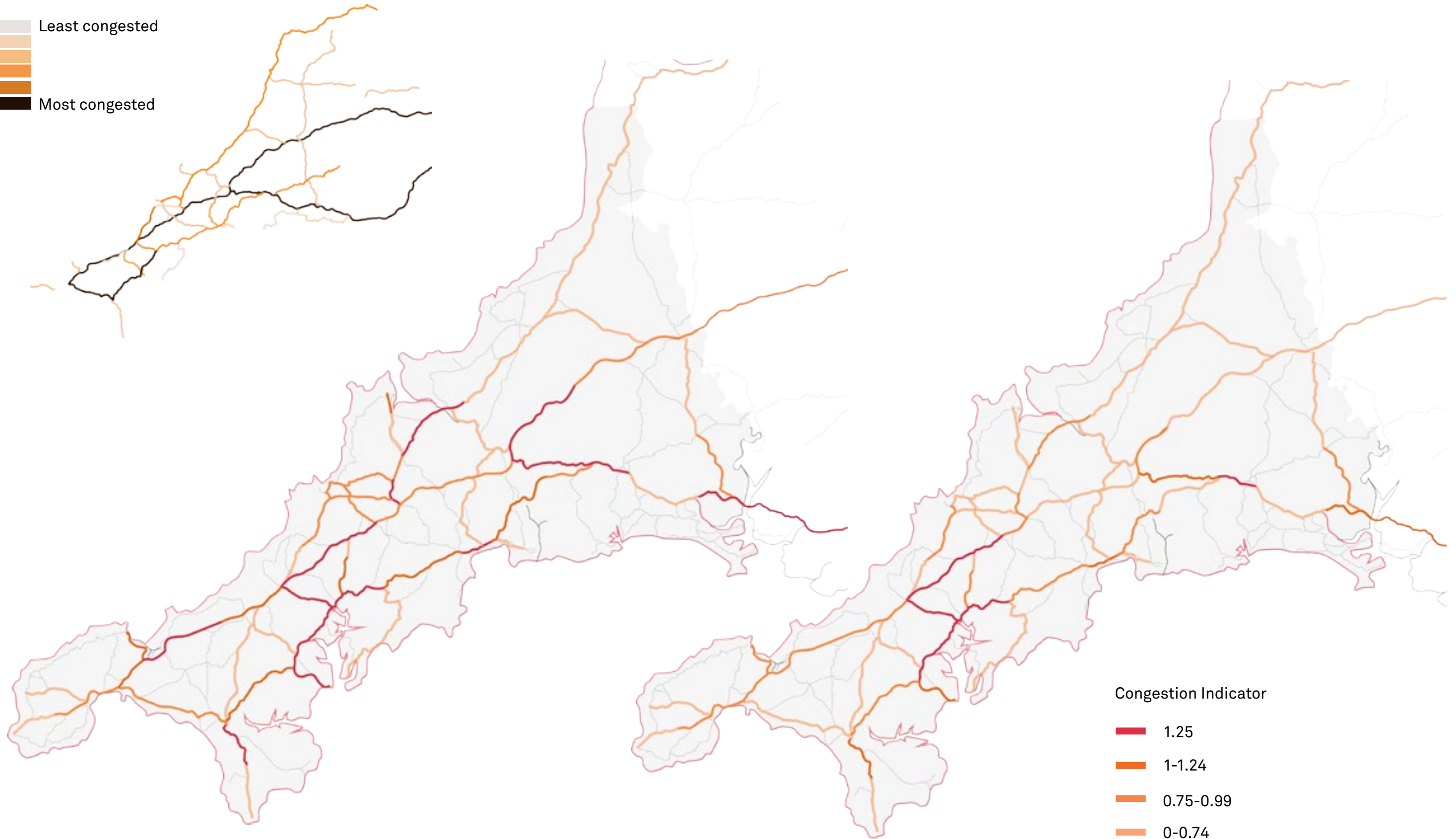
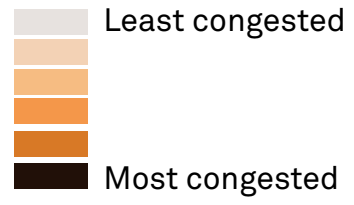



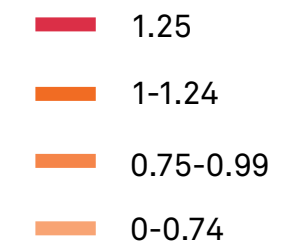



Congestion Indicator







Road Network Fragility

Congestion is a problem both in high and low season. This map compares the change in congestion between high and low season and the areas congested all year round. Flooding or blockages at the fragile points shown in the map can significantly disrupt access to Cornwall. In 2012, flooding cut off Cornwall from the rest of the UK.

-  Roads
-  Train lines
-  Areas flooded historically
-  Primary routes to Cornwall
-  Fragile points in the Infrastructure
-  2012 Flooding

Congestion change between peak and off peak

-  3 step change
-  2 step change
-  1 step change
-  No change
-  Congested all year round

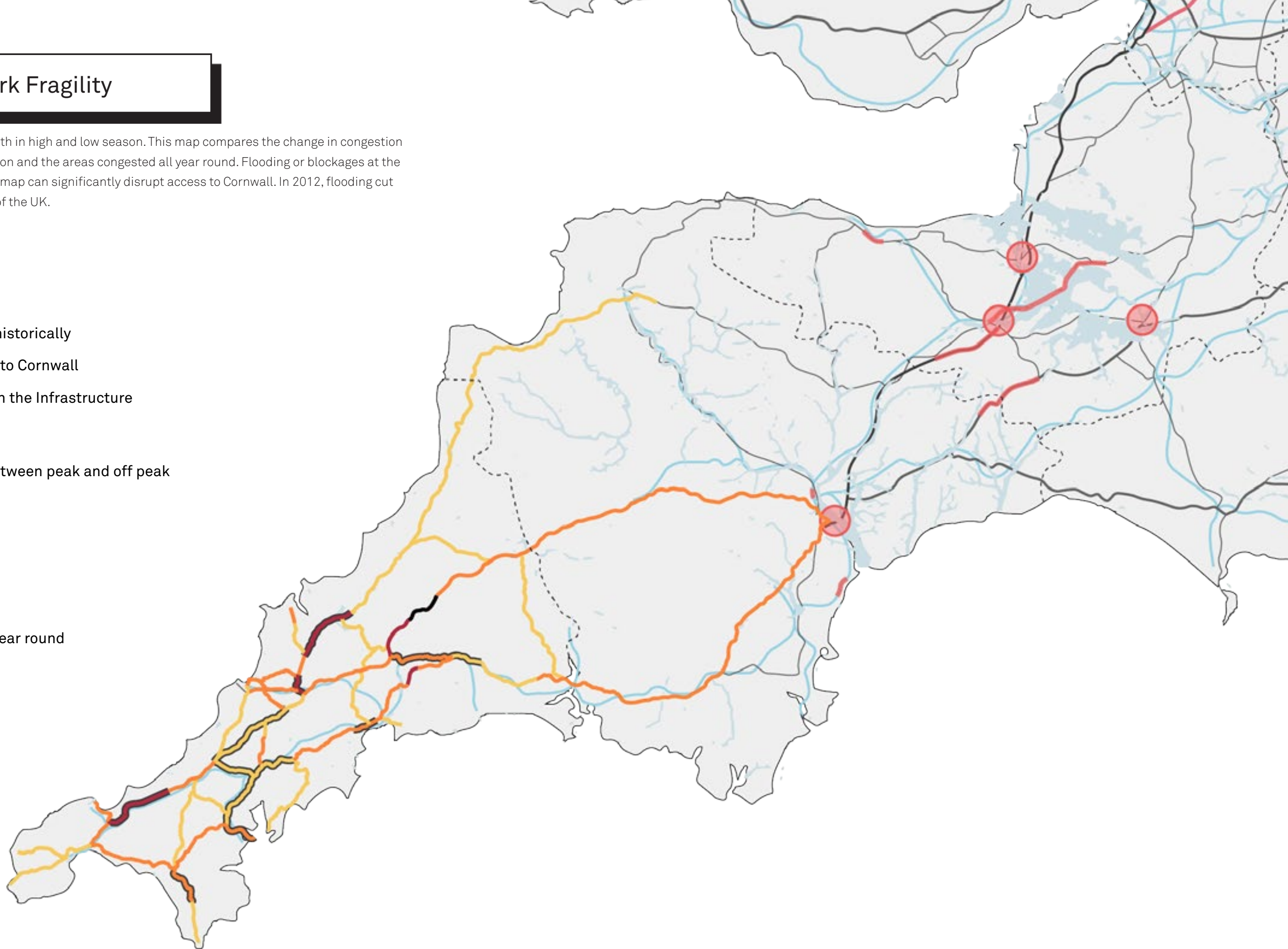

Public Transport

This page shows accessibility to public transport. The majority of Cornwall does not have access to public transport every 30 minutes.

Area accessible to 30 minute frequency public transport



Area accessible to 60+ minute public transport



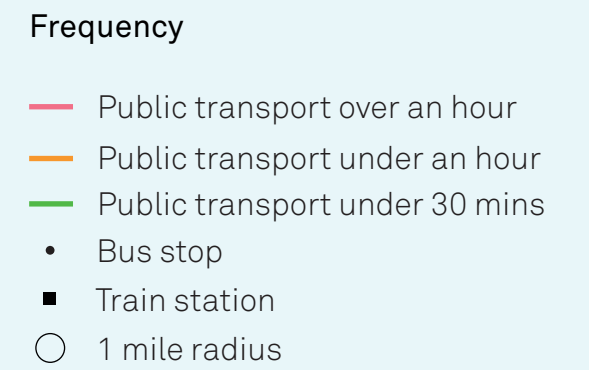
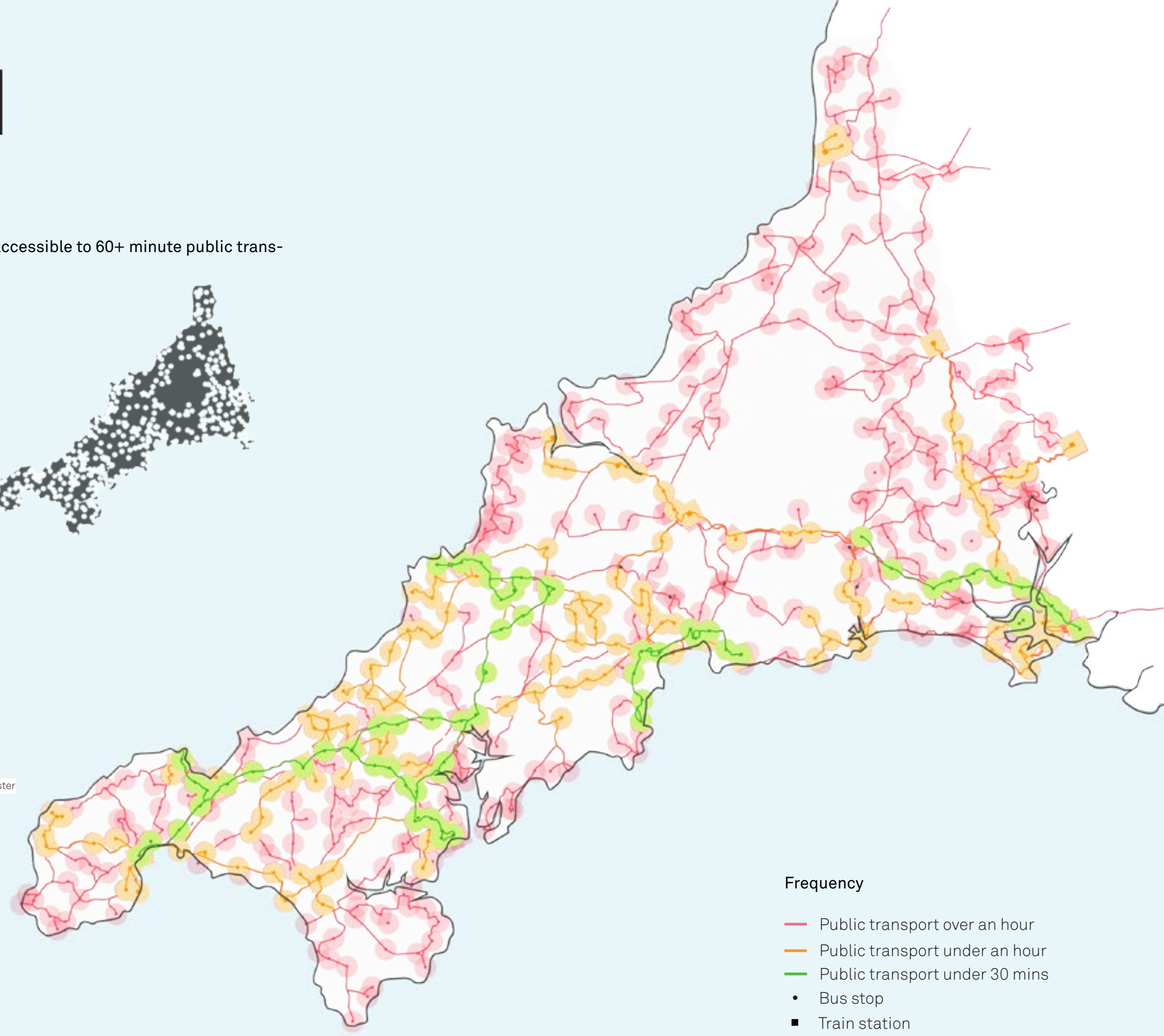
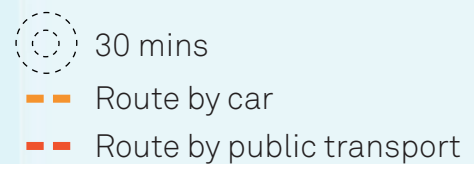
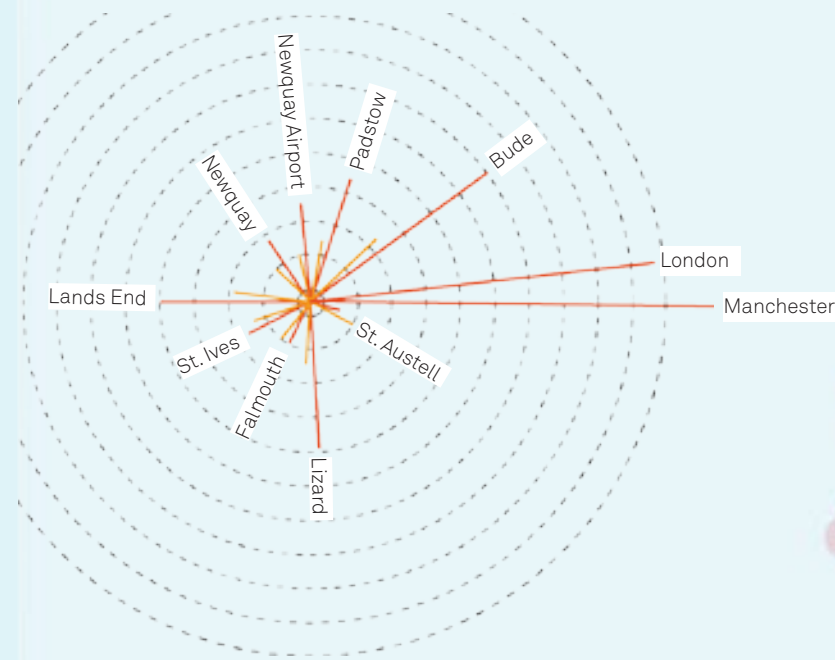

Comparison of travel times from Truro by car and public transport



Car Ownership

Car ownership is higher than the UK average of 76%. In low density areas, travel by car appears to be the quickest way to travel in and around Cornwall. Due to road network capacity, this can lead to problems of congestion in high season.

-  <50% of households have a car
-  50-75% households have a car
-  75-100% households have a car

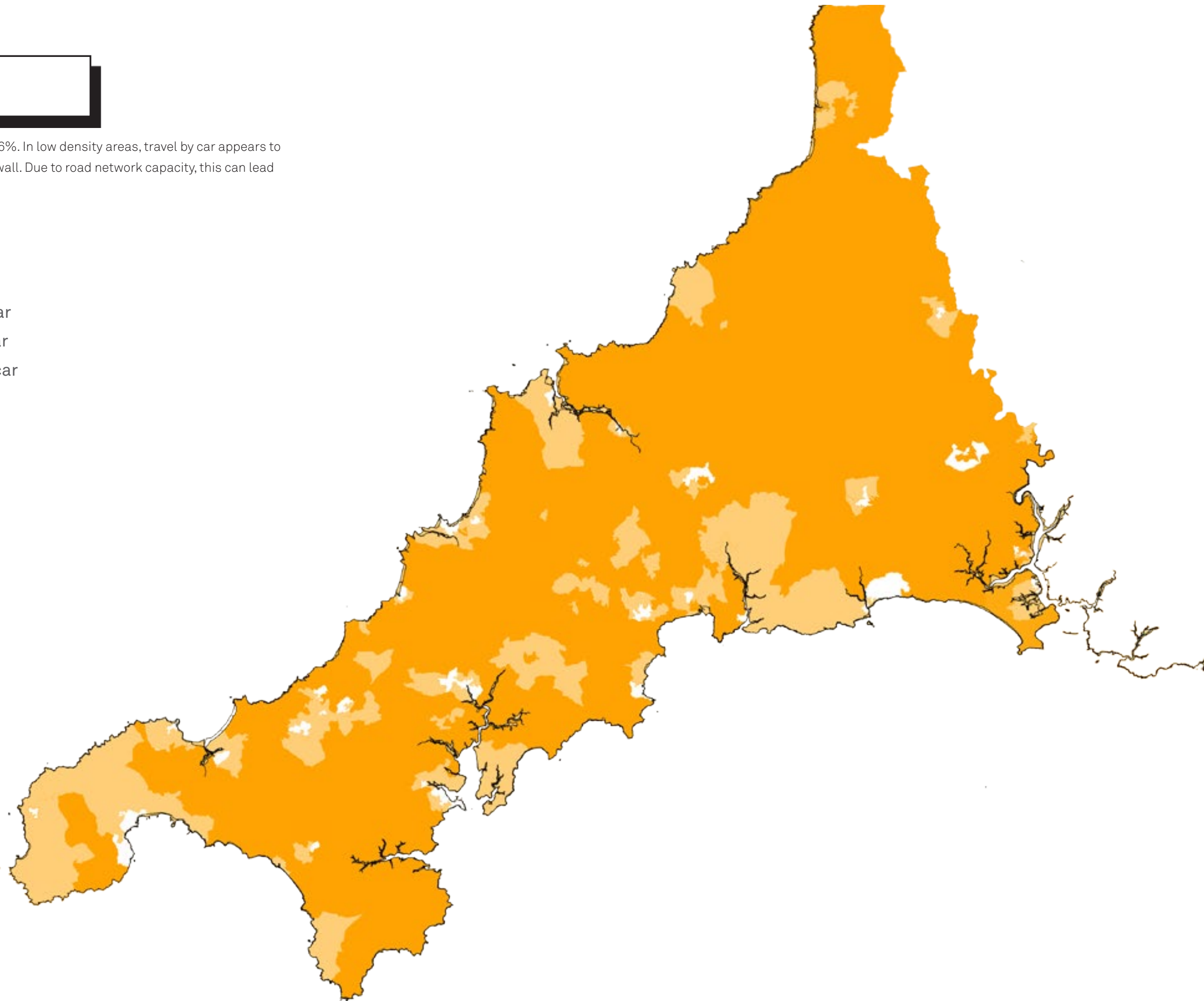

Accessibility to Hospitals

Travel time to hospitals

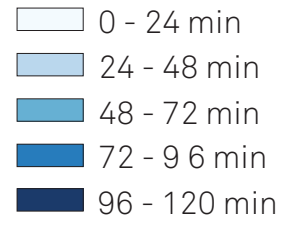

Isles of Scilly



Walking/ Public Transport

Cycling

Car

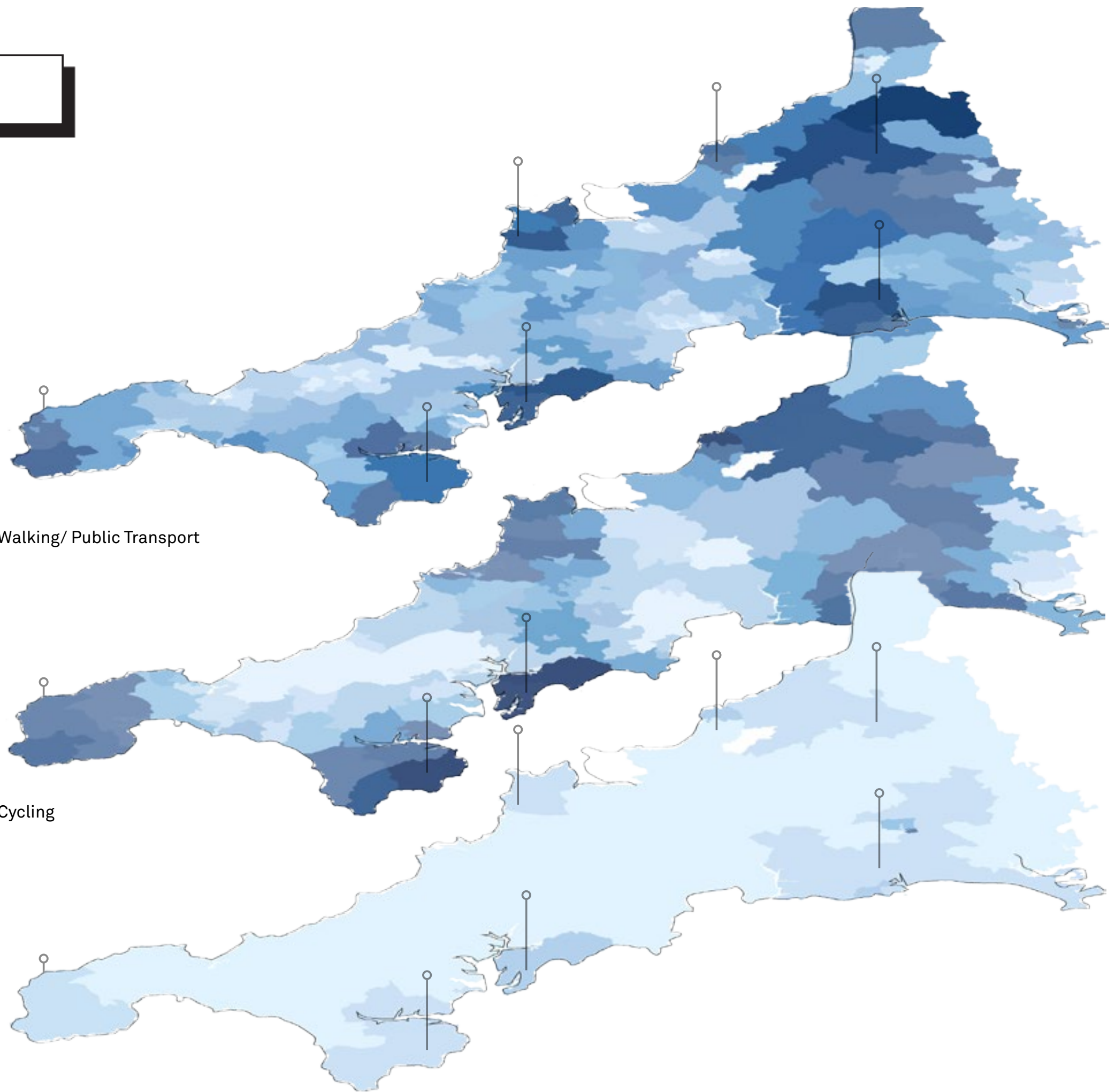

Limitations to Industry

Road width limitation on industrial vehicles

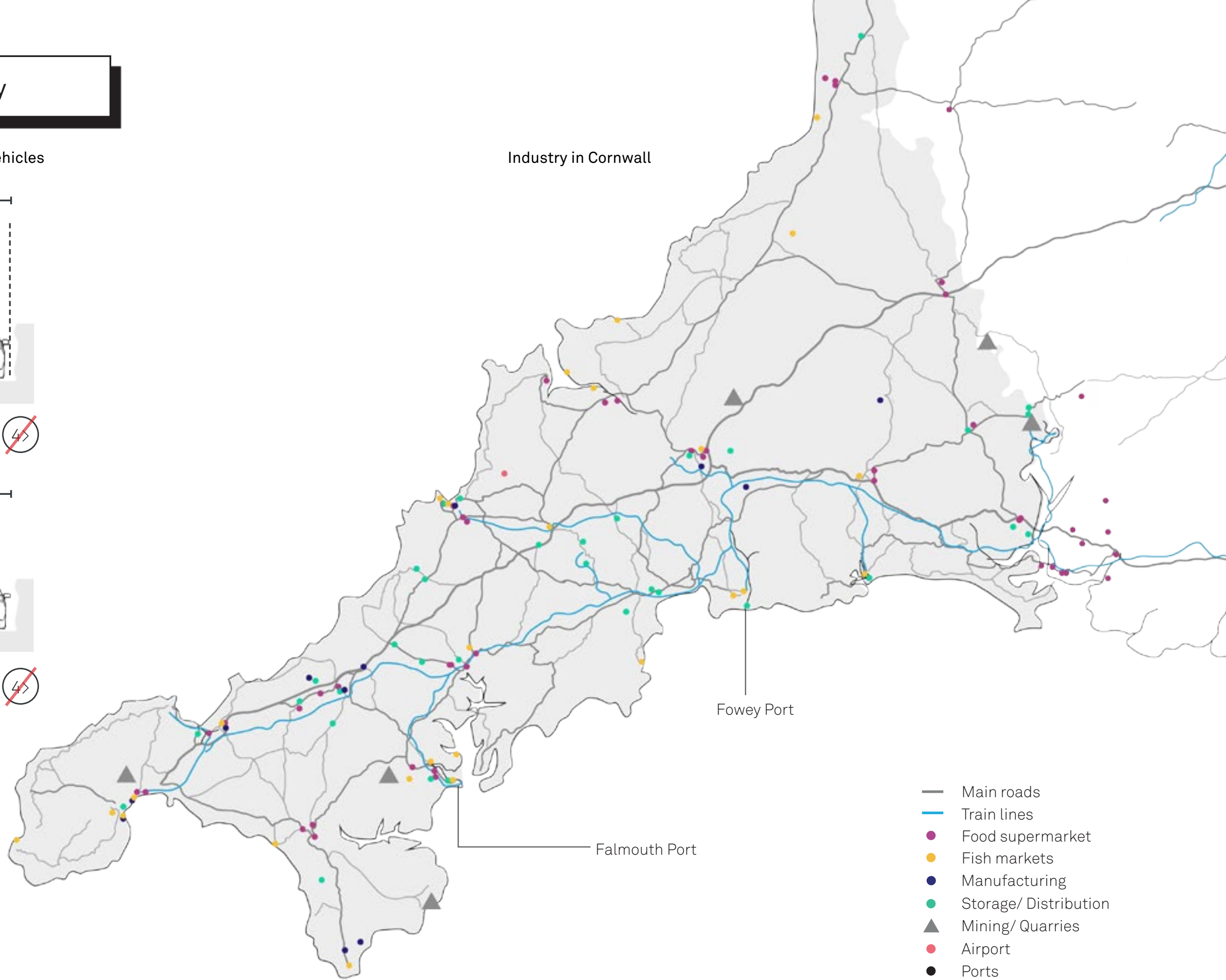
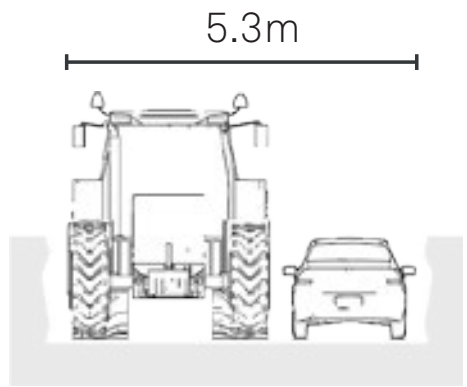
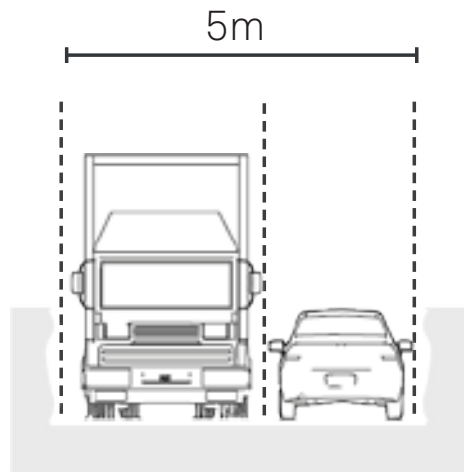

- Main roads
- Train lines
- Food supermarket
- Fish markets
- Manufacturing
- Storage/ Distribution
- ▲ Mining/ Quarries
- Airport
- Ports

Global Fibre Connections

Map showing submarine fibre-optic cable. High-frequency traders now automate many of their trades. Algorithms automatically execute sales and purchases based on triggers in financial data. Every trader has individual investment strategies, but the software often uses the same data. The first orders on the books are the first to be executed and so the quicker the connection, the more money each trader can potentially earn based on lower stock prices.

By creating a new node within the Stock Exchange network in Cornwall approximately 3 valuable milliseconds can be saved by comparison to the existing infrastructure to London. Although exact figures vary, experts claim that a millisecond advantage could be worth £63m a year to the bottom line of a large hedge fund.

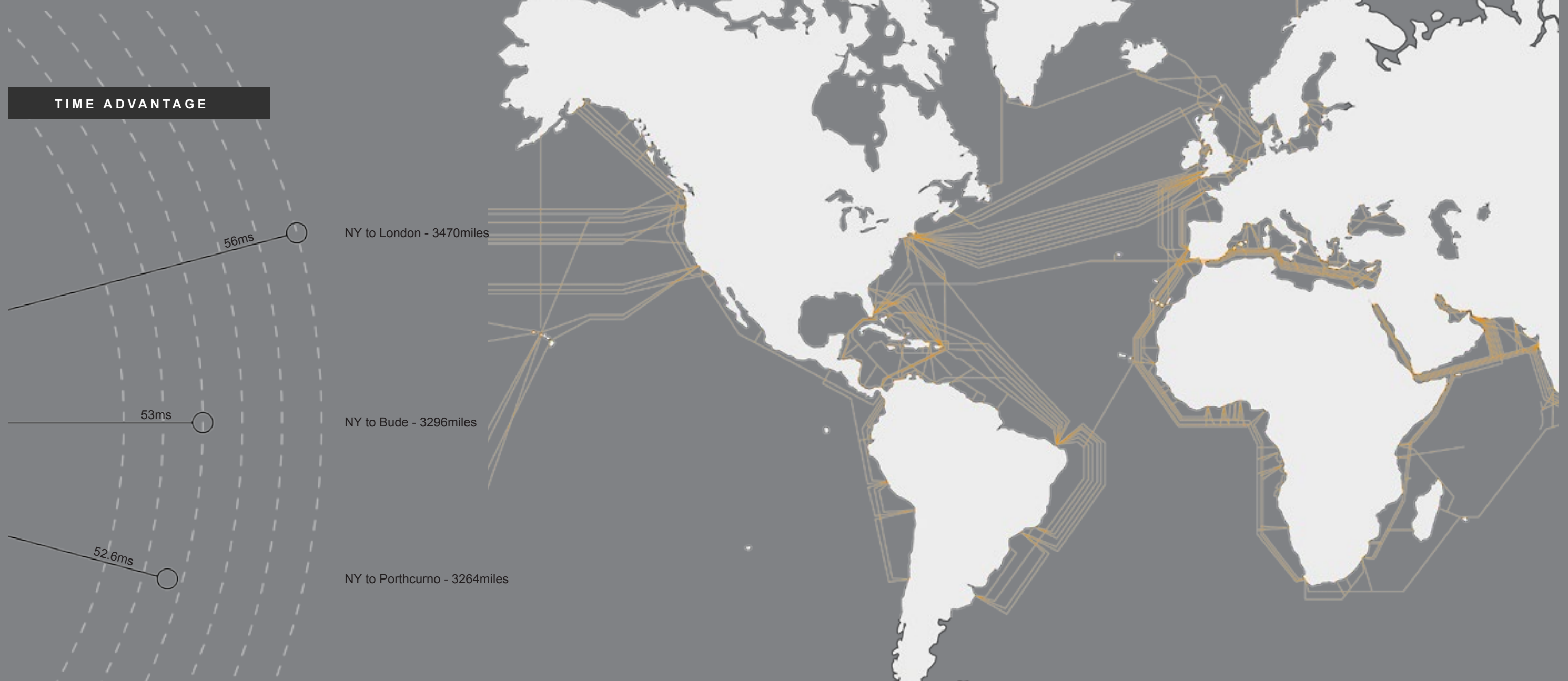

TIME ADVANTAGE

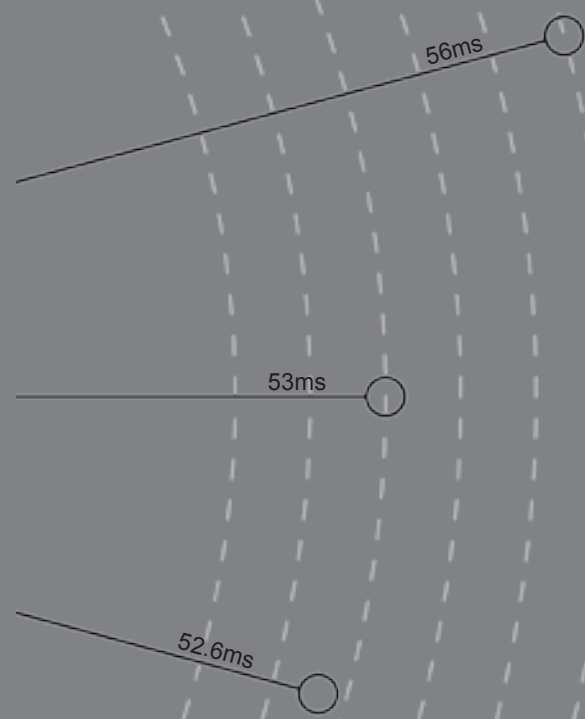

Broadband Speeds

Ofcom 2013 average broadband

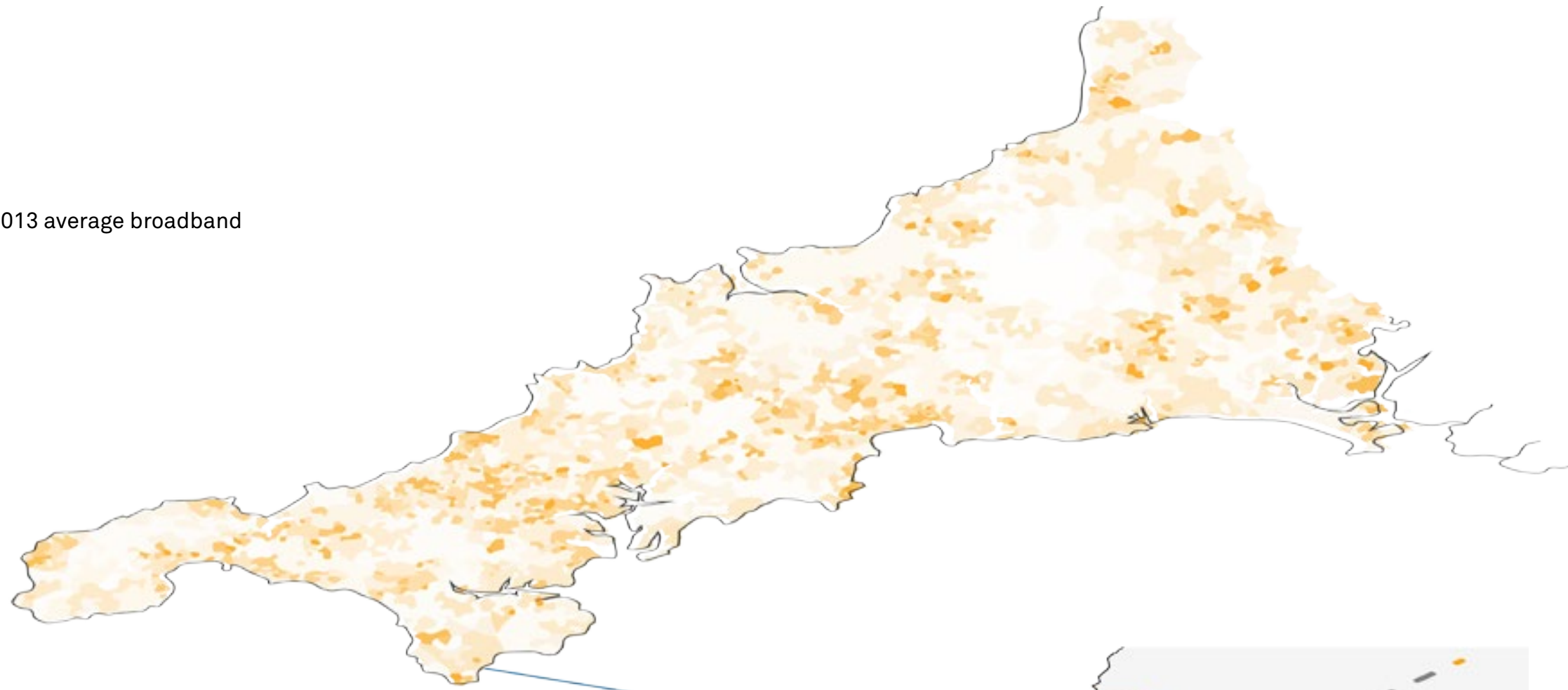

Think broadband 2016

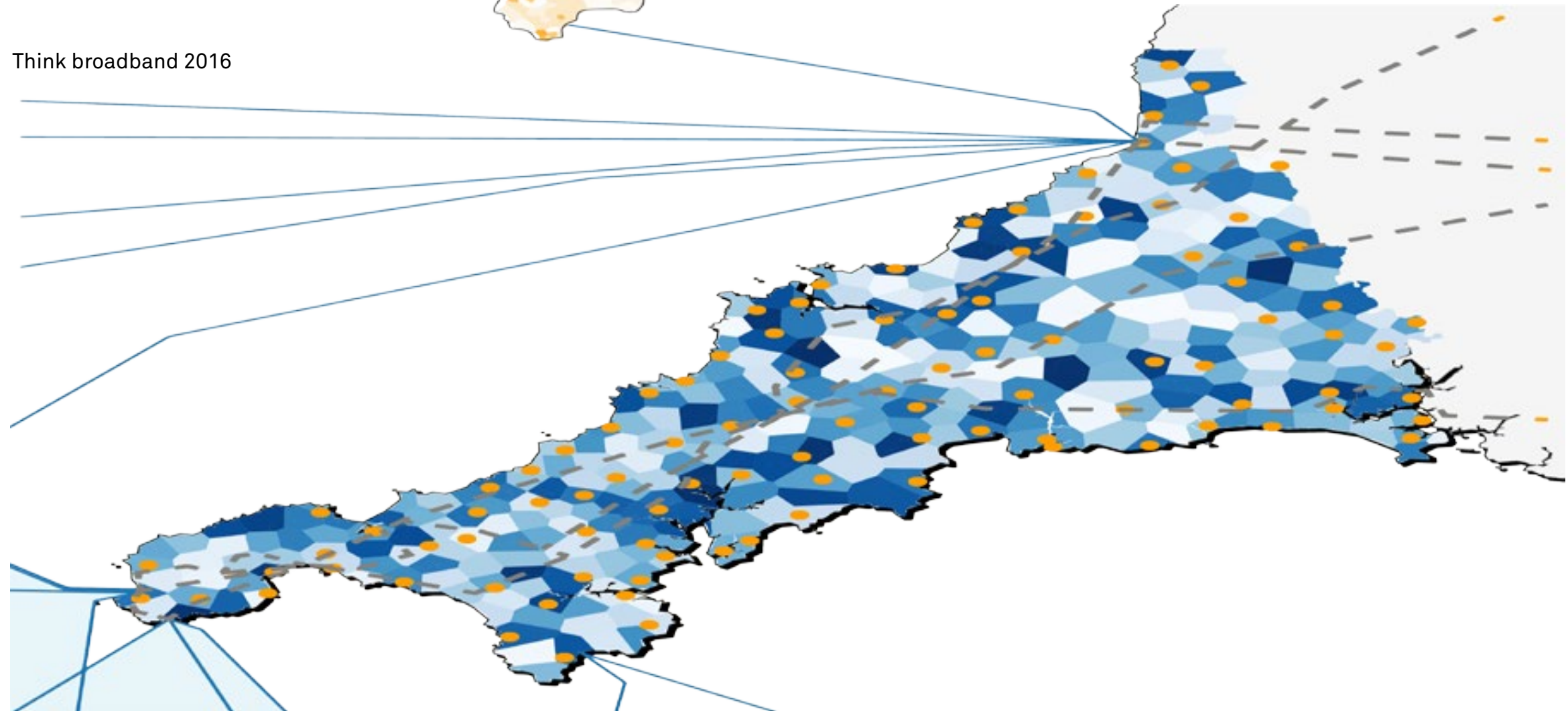

- 15Mb/s
- 30Mb/s
- 50Mb/s
- 100Mb/s
- Exchange centres
- Land cables (Virgin)
- Transatlantic cables

LSOA Deprivation and Limited Access

This map shows areas that have poor physical and virtual access mapped onto LSOA deprivation. The areas highlighted red show with deprivation and poor broadband speeds.



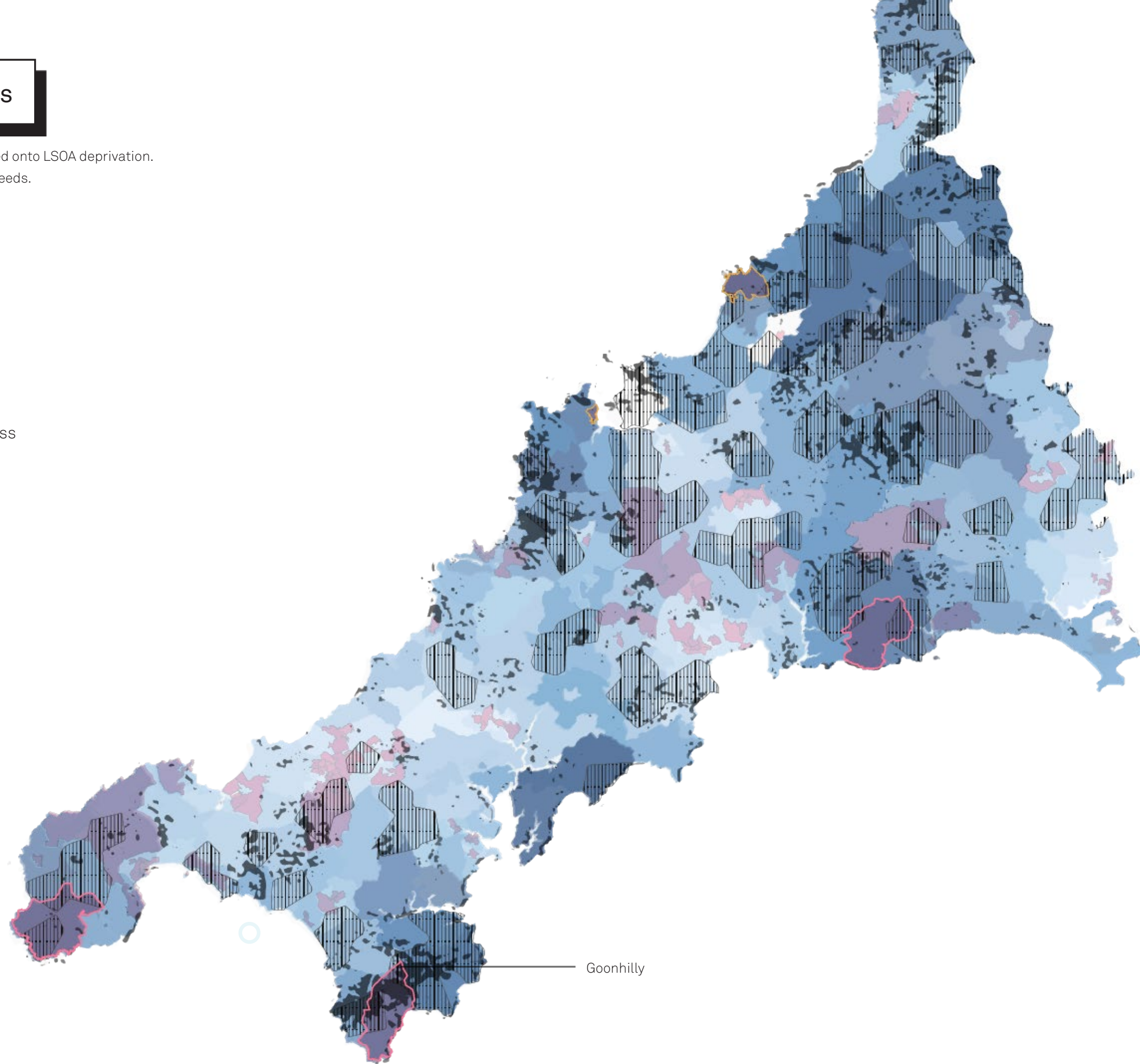

- 0 - 24 min
- 24 - 48 min
- 48 - 72 min
- 72 - 96 min
- 96 - 120 min
- LSOA deprivation
- No 3g across all providers
- Wifi under 12Mb/s
- Most deprived areas with poor virtual & physical access
- Most deprived area with poor physical access

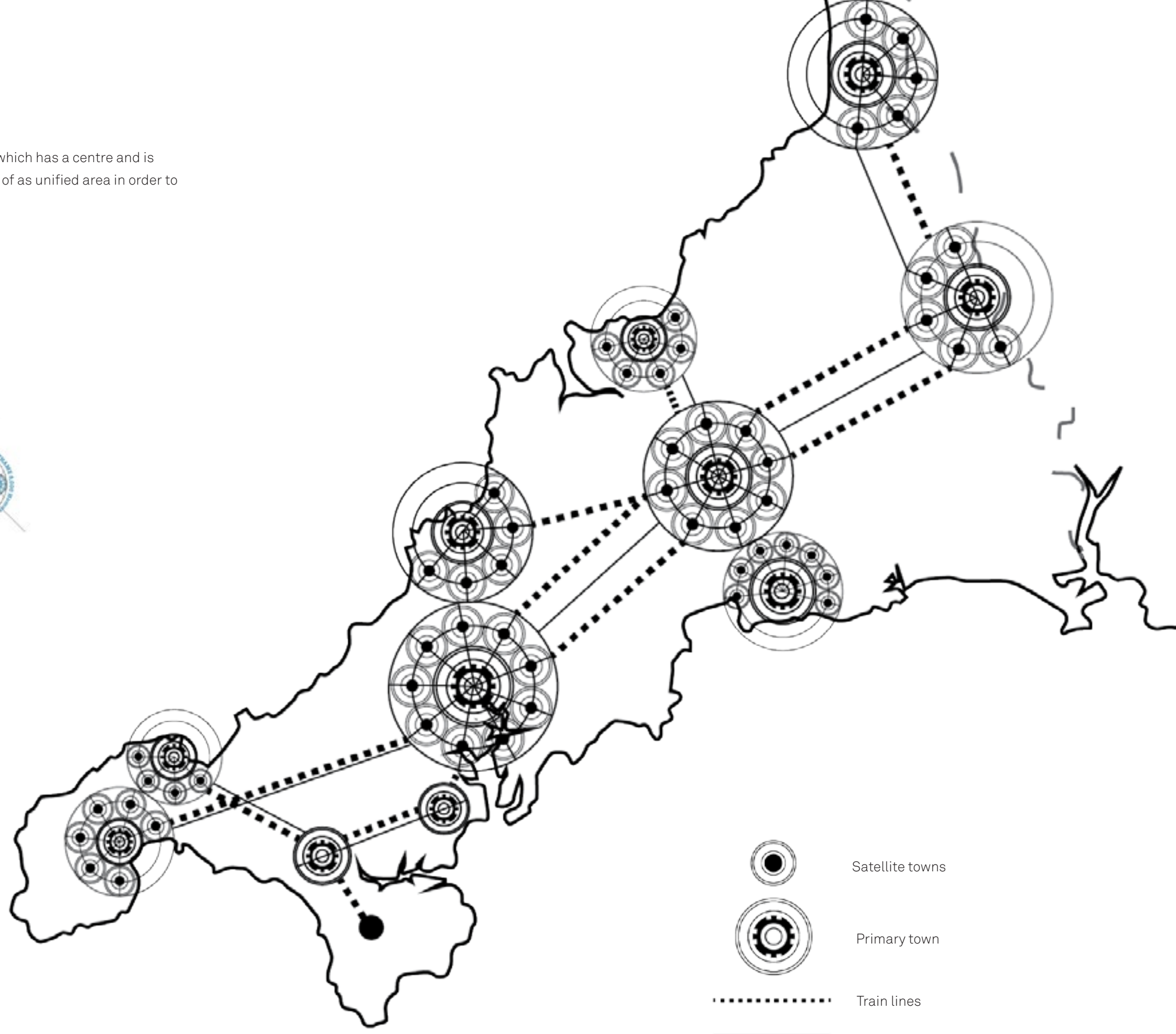
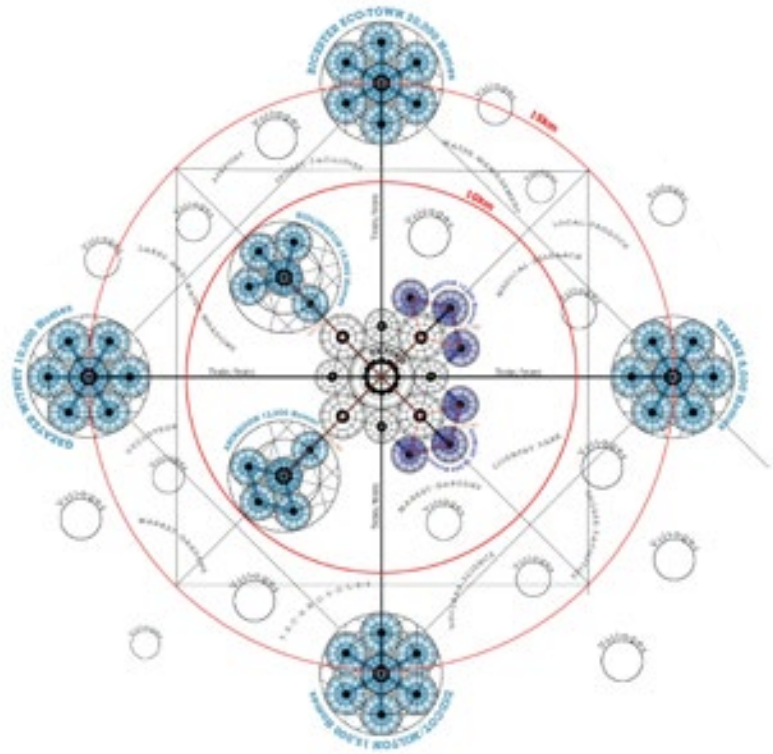

Cornwall, Garden City?

Is Cornwall a dispersed Garden City? A garden city is an urban area which has a centre and is surrounded by satellite villages or towns. Cornwall could be thought of as unified area in order to address some of its problems in regards to connectivity.



-  Satellite towns
-  Primary town
-  Train lines
- 

E N E R G Y

+

P O W E R

UK ENERGY FUTURE

The UK is at a pivotal moment for investing in the future of its energy system. Over a half of all UK power stations are expected to close by 2030. The demand for electricity is also expected to rise despite increased efficiency. Potentially, this is a serious problem for the security of energy supply in the UK, yet it poses an interesting questions about how this shortfall will be met.

Renewables and imported energy are earmarked solutions. This challenge presents itself as a great opportunity for the UK and more specifically Cornwall. How might Cornwall respond to this energy challenge and lead the way in providing a solution for the UK? Can a decentralised and smart energy grid coupled with greater consumer ownership and engagement shape the future of energy production and consumption in the UK?

ELECTRICITY SUPPLIED BY FUEL TYPE. UK. 1980 TO 2035

Data from DECC Updated energy and emissions projections (2015)

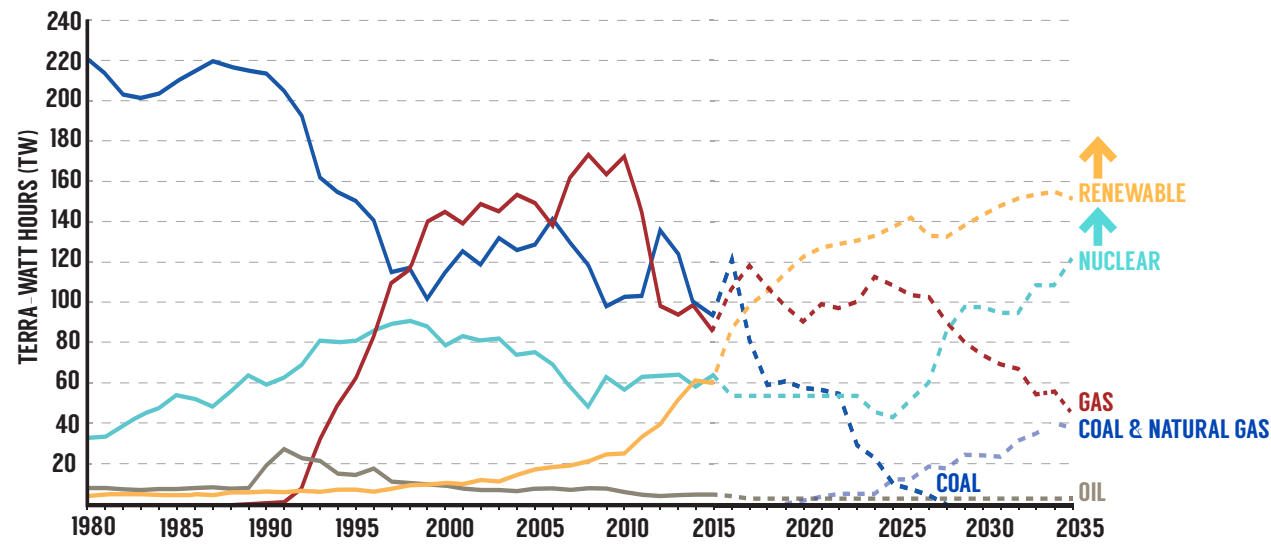

ENERGY IMPORT DEPENDENCY. UK. 1980 TO 2015

Data from DECC Updated energy and emissions projections (2015)

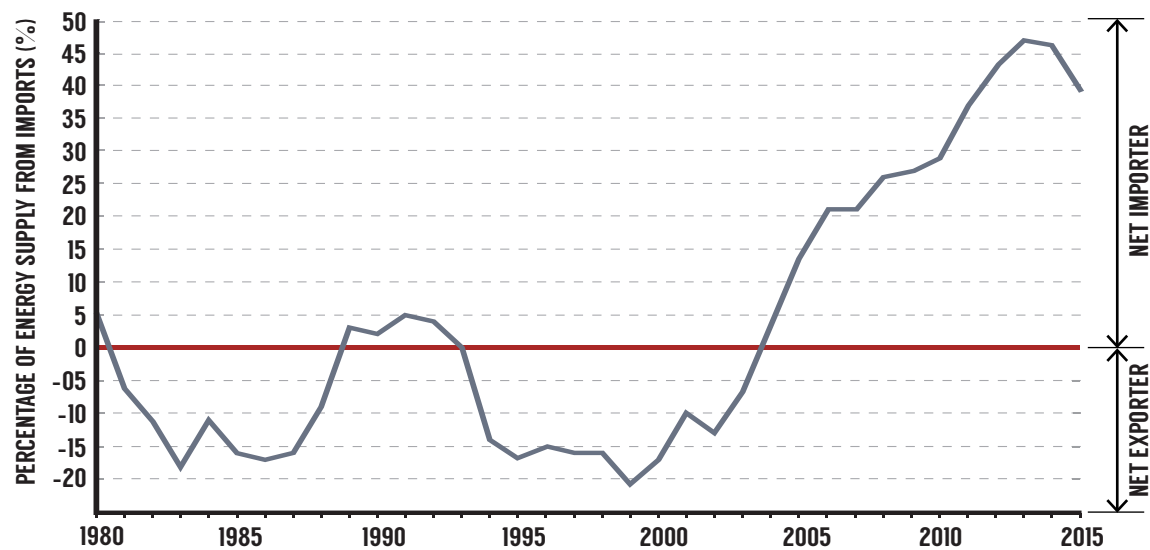

Over the last 20 years the UK has transformed from a net exporter of primary fuels to a net importer, with the production of primary fuels reducing by over 50% between 1995 - 2015. However, total energy consumption dropped between 1995-2015. Potential reasons for this could be generational or economic factors, as well as being influenced by increased cost and efficiency. Additionally, 28% of energy was wasted or lost in 2015 through production and transmission.

DIAGRAM EXPLORING THE RELATIONSHIP BETWEEN SUPPLY AND DEMAND IN THE UK

Data from DBEIS Supply and Use of Fuels (2016). The data was converted from Mtoe to TWh using the conversion 1,000,000 toe = 11.63 TWh

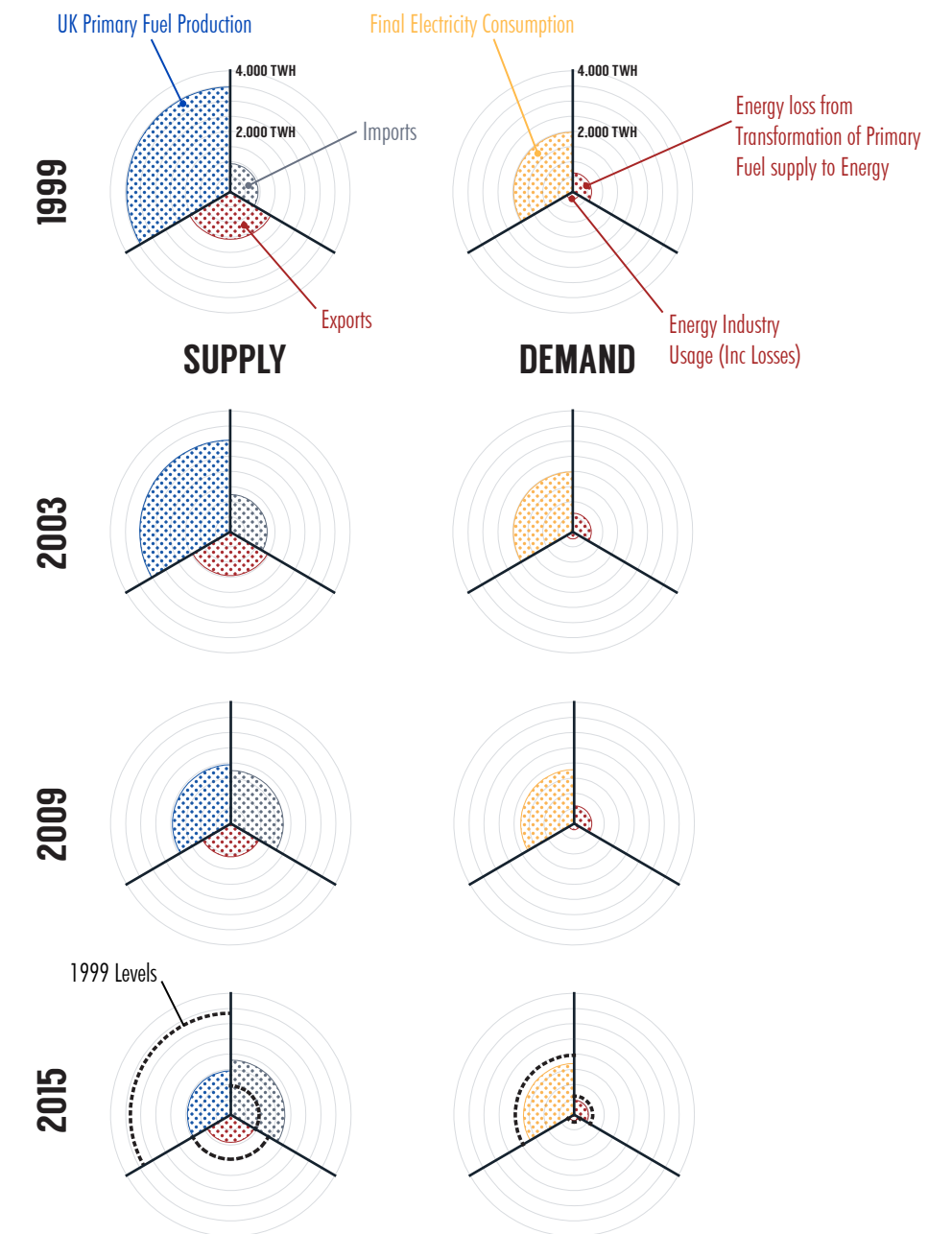

NATIONAL GRID AND SMART CORNWALL

These diagrams explore existing and potential energy grids. In smart grids, the production of energy is primarily localised and continually monitored with inefficiency sensors indicating when local supply cannot meet demand so the supply can be diverted to regional production. The smart use of energy can also be adopted with energy storage systems employed during times of surplus production and to bolster supplies during periods of low production.

A smart grid could potentially offer a number of socioeconomic benefits, such as lower electricity costs and a decrease in the cost of power generation regulation.

TRADITIONAL CENTRALISED ENERGY GRID

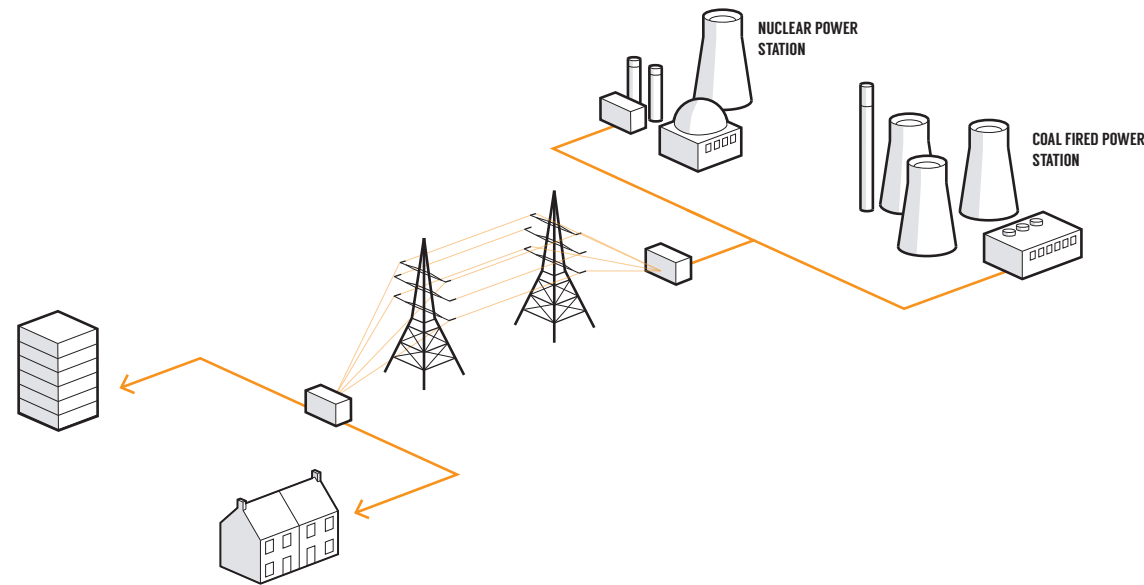

TRADITIONAL CENTRALISED GRID (ONE-WAY)

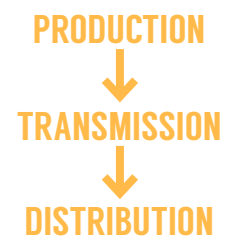

CURRENT CENTRALISED GRID (ONE WAY-CONSTRAINED)

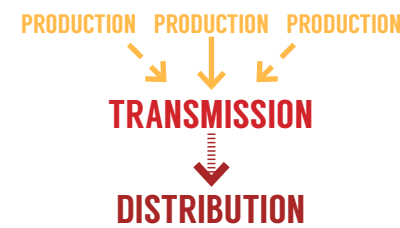

[FUTURE] DECENTRALISED ENERGY GRID

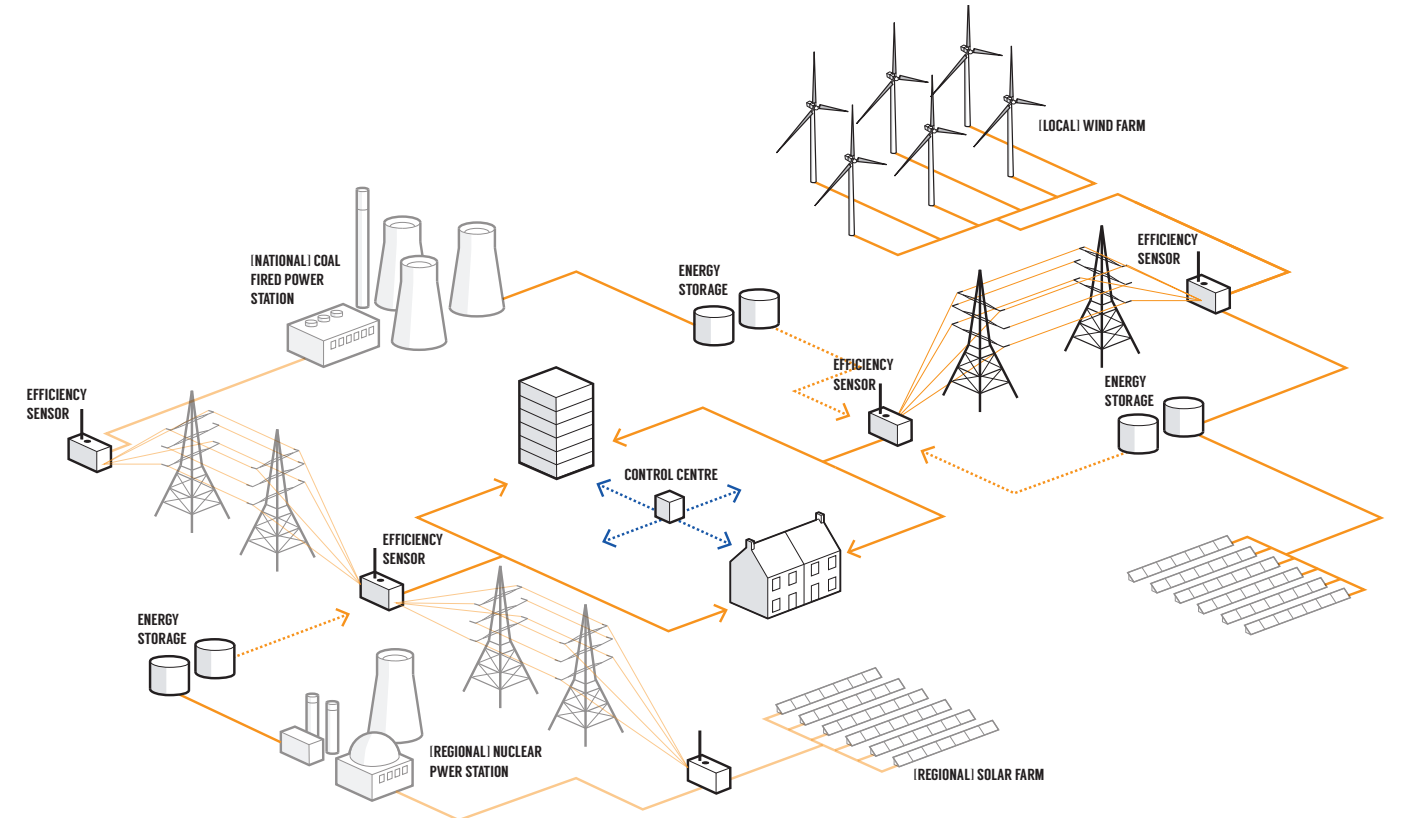

CONSUMER RELATIONSHIPS WITH THE NATIONAL GRID

Diagram showing consumer relationships in the current national grid and in a potential future national 'smart' grid.

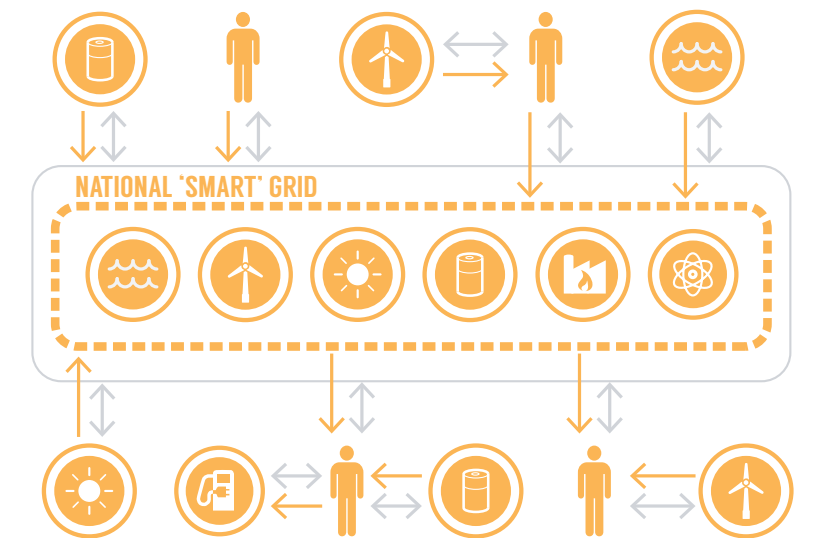
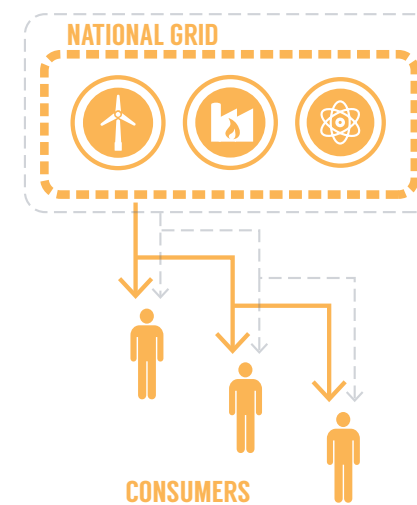

[FUTURE] LOCALISED SMART GRID

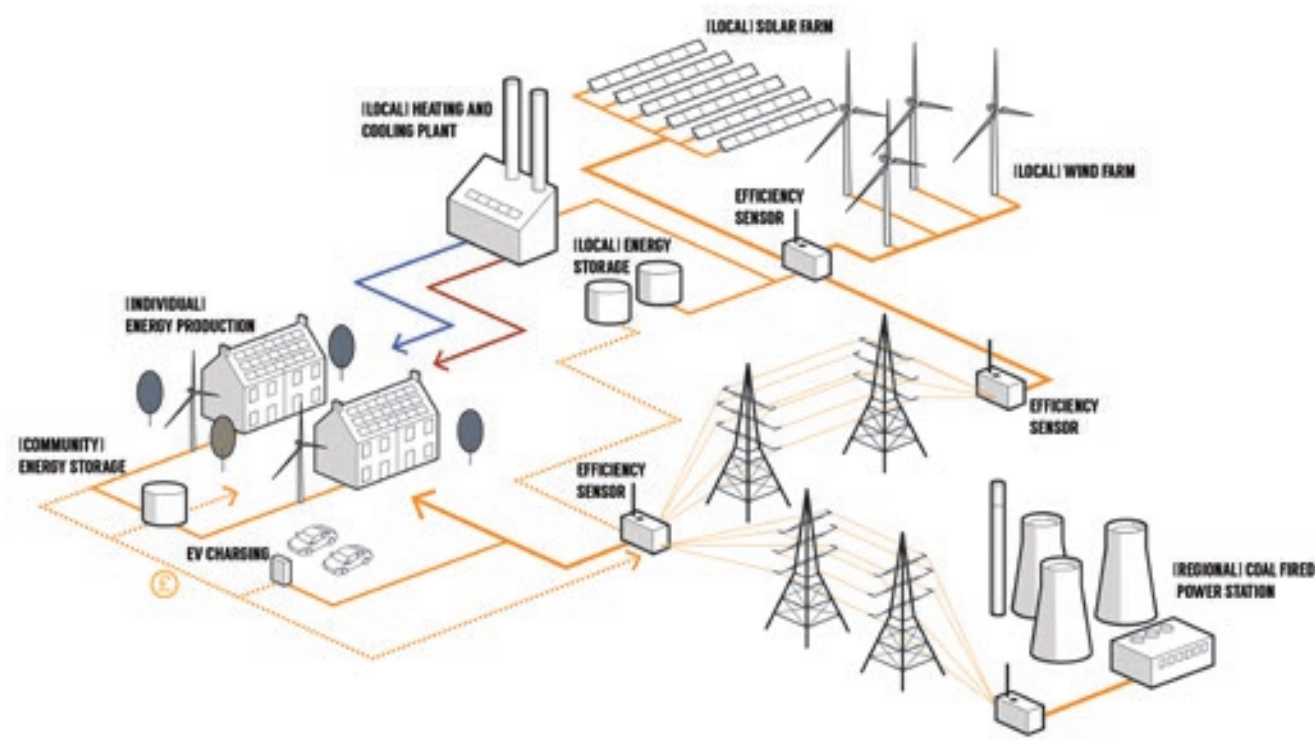

HOW A DECENTRALISED CHP NETWORK COULD WORK IN CORNWALL

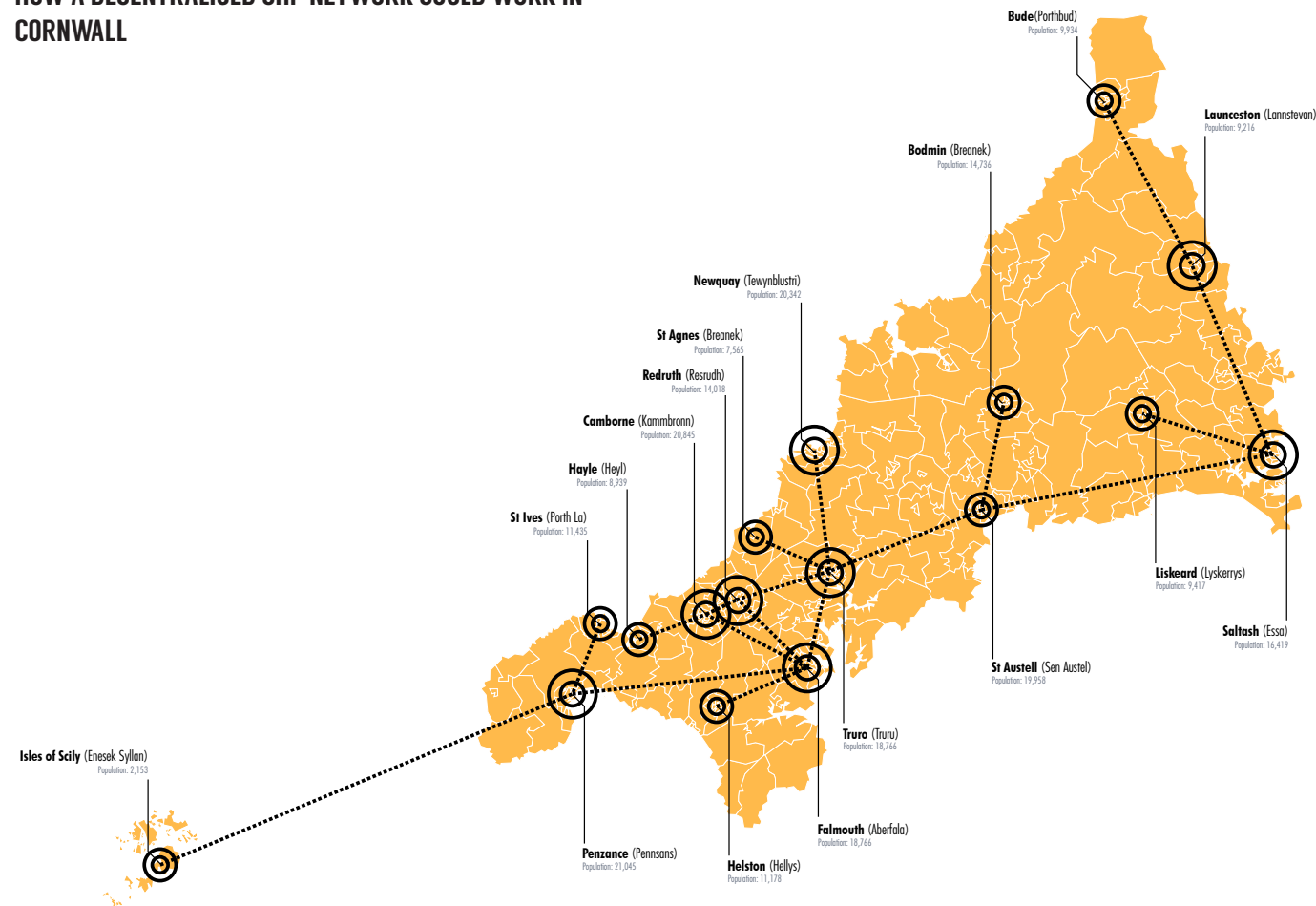

DATA MAPPING CORNWALL

ENERGY CONSUMPTION IN CORNWALL

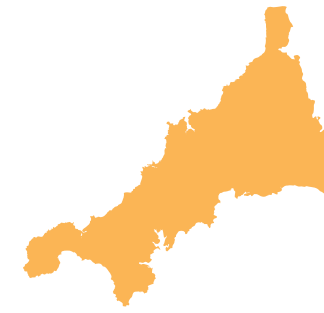

TOTAL CORNWALL CONSUMPTION
12.026GWH



TOTAL DOMESTIC CORNWALL CONSUMPTION
3.866GWH

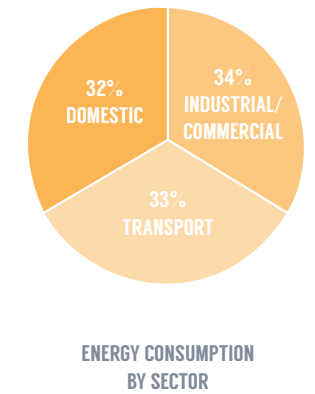
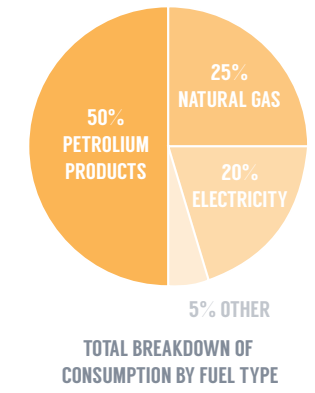

TRANSPORT

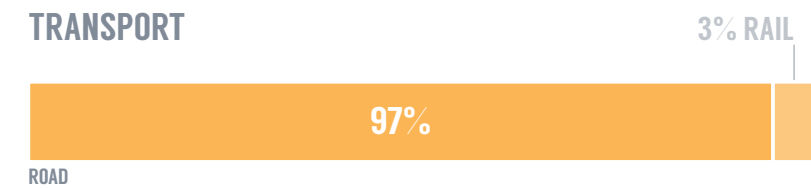

ROAD TRANSPORT

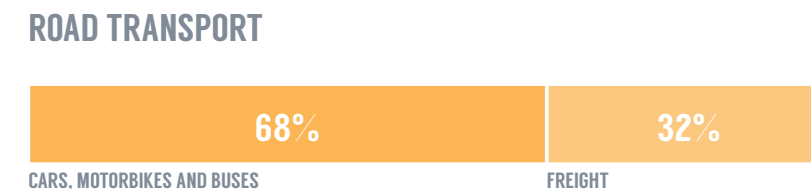

DOMESTIC

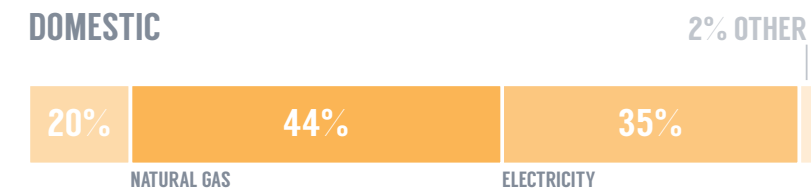

DOMESTIC USAGE

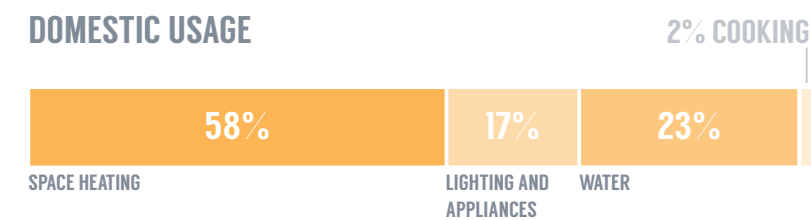

ENERGY + POWER

FOOTPRINT AND CAPACITY IN CORNWALL

FOOTPRINT REQUIRED TO PRODUCE CORNWALL'S TOTAL YEARLY ENERGY CONSUMPTION

This 3D study explores the relationship between the area required for renewable technologies and the amount of capacity generated in order to deliver Cornwall's total yearly energy consumption. Each square of the grid equals 10km². Wind technologies are inefficient for the amount of space used, however geothermal and solar PV panels demonstrate a high capacity on a small footprint. However, it is worth noting that land occupied by wind farms can simultaneously be used as agricultural land, whereas solar farm space is dominated by the technology.

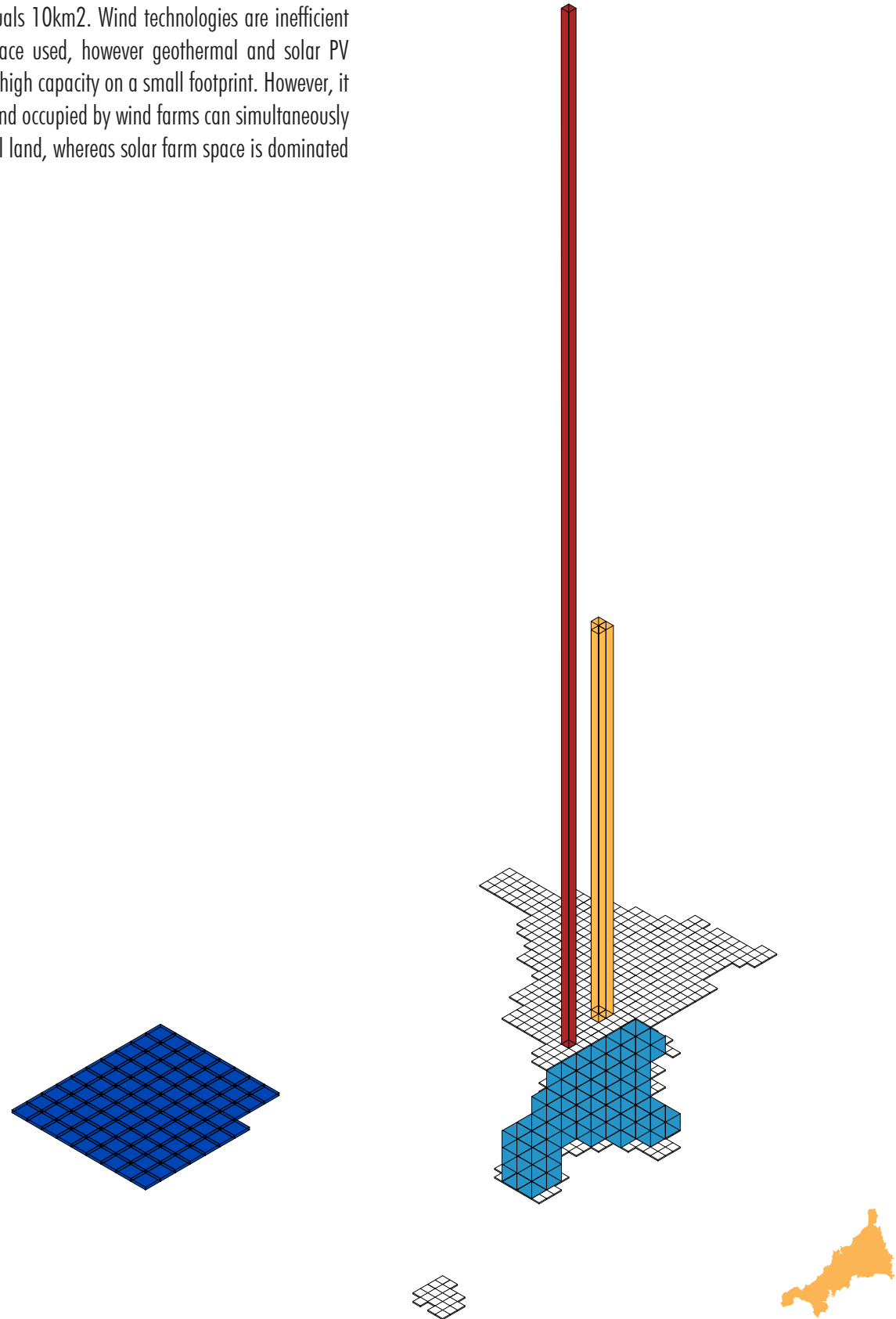







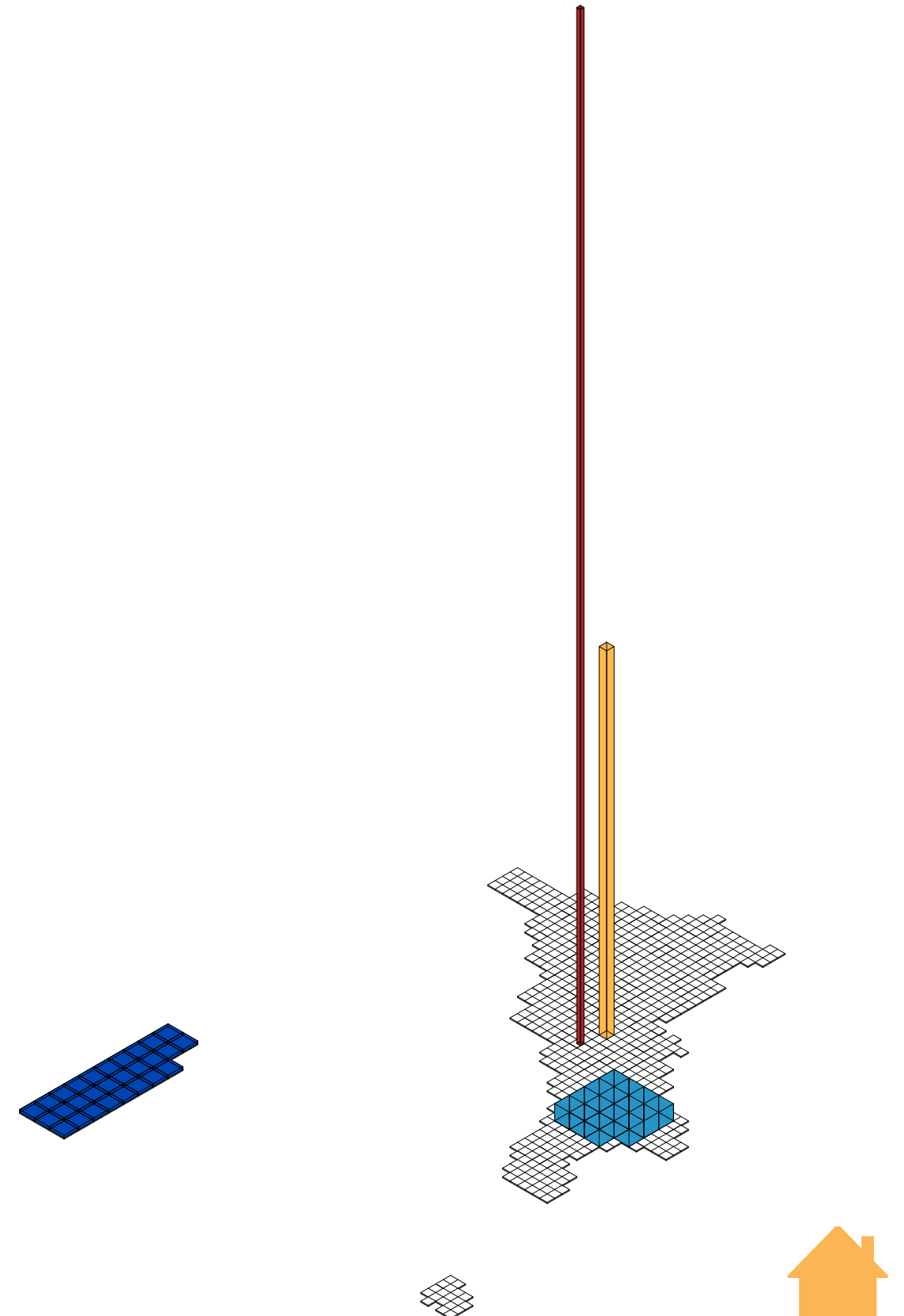



















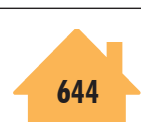
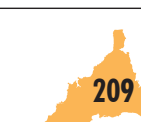

DOMESTIC FOOTPRINT AND CAPACITY

FOOTPRINT REQUIRED TO PRODUCE CORNWALL'S DOMESTIC YEARLY ENERGY CONSUMPTION

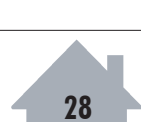
- Offshore Wind Power
- Onshore Wind Power
- Solar Power (PV Panels)
- Geothermal Energy



ENERGY PRODUCTION POTENTIAL

| | Total Capacity (GWh) | Dom. Capacity (%) | County Capacity (%) | Footprint (km ² /MW) | Efficiency (%) | Lifespan (Years) |
|--------------------|----------------------|--|--|--|----------------|------------------|
| WIND OFFSHORE | 3527 |  90 |  29 |  0.16 | 25 | 20-25 |
| WIND ONSHORE | 4073 |  104 |  34 |  0.10 | 30 | 20-25 |
| SOLAR | 883008 |  22,840 |  7,342 |  0.0012 | 10 | 20-25 |
| WAVE | 1357 |  34 |  10 |  0.0005 | 25 | 15-20 |
| TIDAL | 328.5 |  8 |  3 |  0.0005 | 25 | 75-100 |
| HYDRO | 1 |  0.03 |  0.01 |  0.0010 | 60 | 50-100 |
| GEO THERMAL | 25228 |  644 |  209 |  0.0015 | 72 | 25-30 |
| BIOFUEL | 309 |  8 |  3 |  0.004 | 24 | 10-20 |
| WASTE INCINERATION | 1086 |  28 |  9 |  0.028 | 33 | 25-30 |
| NUCLEAR WASTE | 8.4 |  0.2 |  0.07 |  0.0004 | 80 | 10 |

| Levelised Cost (£/MWh) | RANK & Composite Index (%) |
|------------------------|----------------------------|
| 121 | 16 5 |
| 80 | 16 5 |
| 160 | 24 2 |
| 500 | 25 1 |
| 450 | 25 1 |
| 150 | 25 1 |
| 100 | 24 2 |
| 130 | 23 3 |
| 125 | 21 4 |
| - | 25 1 |

Methodology

Composite indices have been calculated for each technology, as a weighted average of unified indices. The categories have been given the following weights: Total Capacity: 30%, Footprint / Visual Impact: 25%, Cost: 20%, Efficiency: 15%, Lifespan: 10%. The percentages have been designated in order of importance, with capacity greatest as it represents potential energy produced, followed by footprint, in order to prioritise considerations of visual impact.

The following have been considered:

Total Capacity (GWh) For purposes of clarity, data from the unconstrained capacities have been used. Higher capacity has been awarded higher scores.

Footprint (m²/MW) Occupation area in order to produce 1MW of electricity. Lower footprint has been awarded lower score as it will have reduced visual impact.

Efficiency (%) The capacity factor of some technologies is weather dependant. For example, solar and wind rely on the right conditions. However, geothermal can provide a constant base load. Higher capacity factors have been awarded higher scores.

Lifespan (Years) The expected lifetime of the technology. Higher lifespan has been awarded high scores.

Levelised Cost (£/MWh) These costs have been extracted from a report by the World Energy Council in 2013. The study reflects the cost ranges for electricity production from each technology as well as the key drivers of projects costs. These include the cost of financing equipment, installation, operating and maintenance and fuel costs. The analysis only covers projects greater than 1MW in capacity, as the economics of smaller distributed generation differ substantially from those of larger projects.

Limitations

Costs fluctuate according to market trends and efficiencies alter between different technology scales. Additionally, lifespans are difficult to discern for newer technologies such as wave and tidal.

There is no clear ranking system for measuring sustainability and this kind of estimation would require a study in itself, as well as sophisticated means to measure. Notwithstanding this, it is important to consider the following:

Biofuel and waste incineration release CO₂ in the atmosphere during the energy production process (however biofuel is carbon neutral).

High-level nuclear waste is problematic. Clay is effective for geological storage because it is impermeable. Rocks, such as granite, are brittle and crack when they are stressed, which allow water penetration.

The damage of wave technology on marine life has not been accurately measured yet.

Hydro dams may obstruct fish migration and their modification of aquatic habitats.

FUEL POVERTY

UK FUEL POVERTY STATISTICS

11.6% UK IN FUEL POVERTY
14.9% CORNWALL
20.4% ISLES OF SCILLY%
30% ST DENNIS

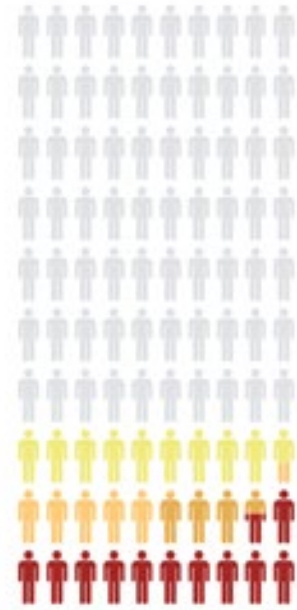
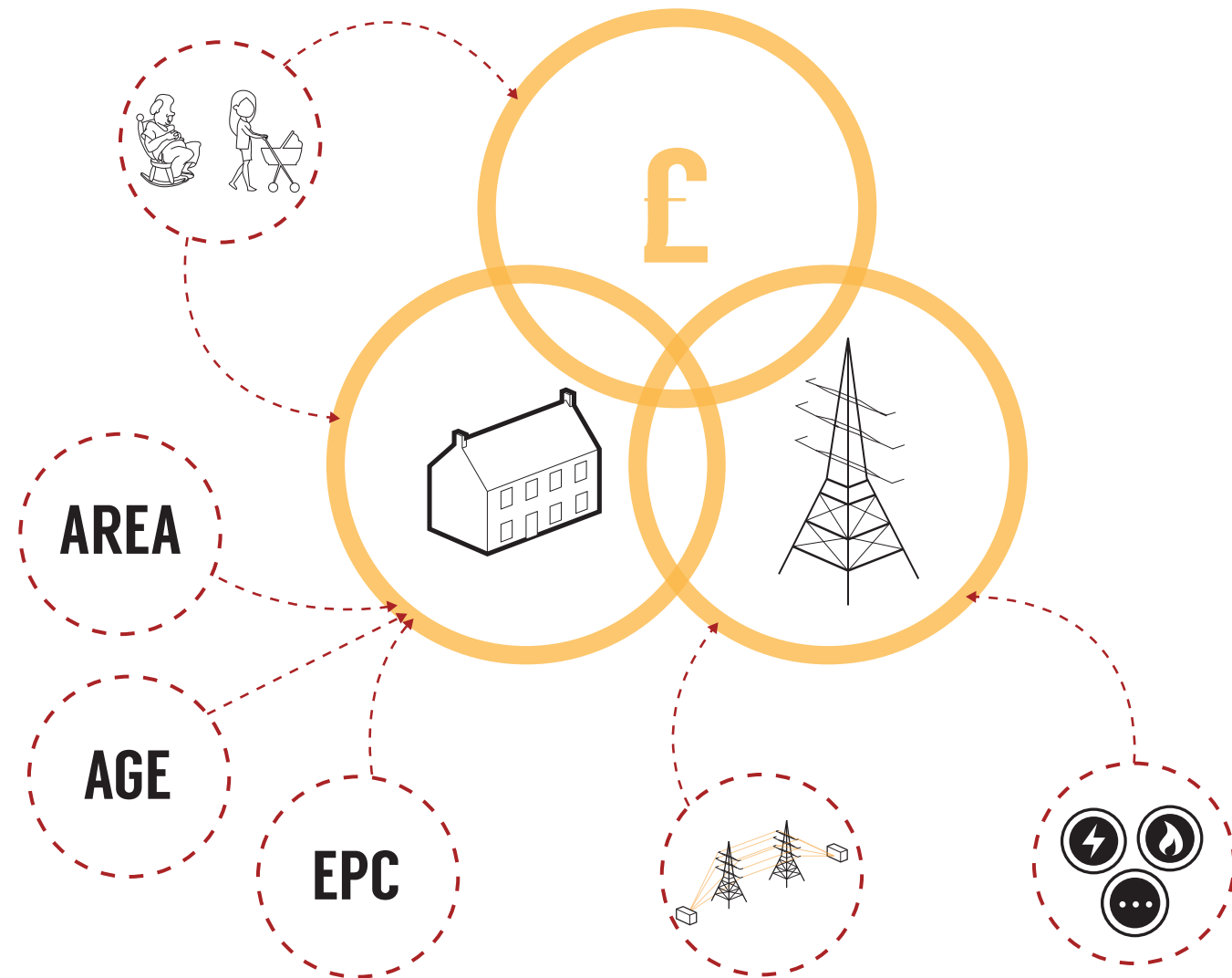
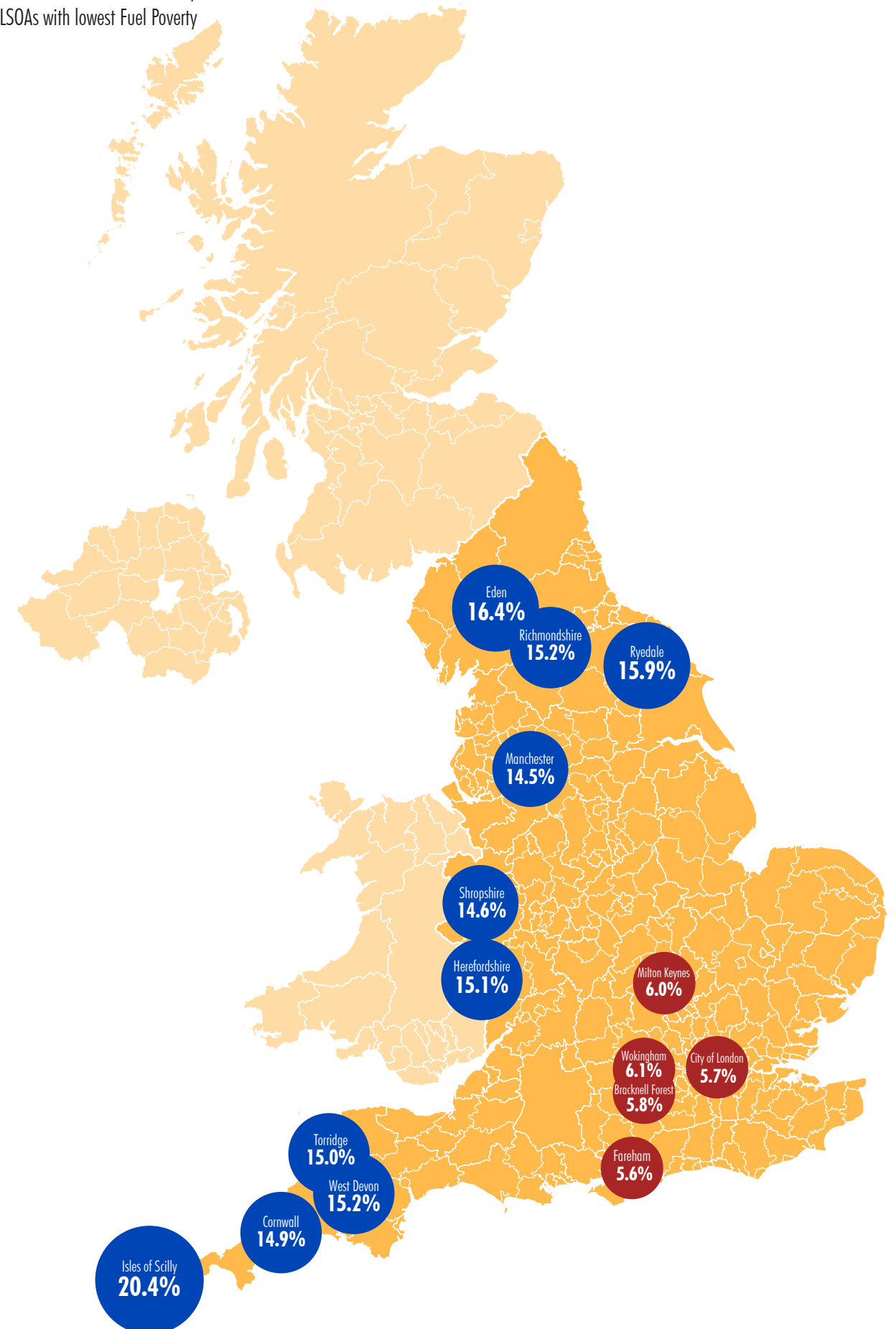

DIAGRAM INDICATING THE MULTIPLE CAUSES OF FUEL POVERTY



PERCENTAGE OF HOUSEHOLDS FUEL POOR IN ENGLAND BY LOCAL AUTHORITY

■ 10 LSOAs with most Fuel Poverty
 ■ 5 LSOAs with lowest Fuel Poverty



FUEL POVERTY IN CORNWALL PER LSOA AREA

- Greatest Percentage of Households in Fuel Poverty
- ↓
- Lowest Percentage of Households in Fuel Poverty
- Top 5 LSOA's with Highest Percentage of Fuel Poverty
- Bottom 5 LSOA's with Lowest Percentage of Fuel Poverty
- + Major Town
- ★ Administrative Centre

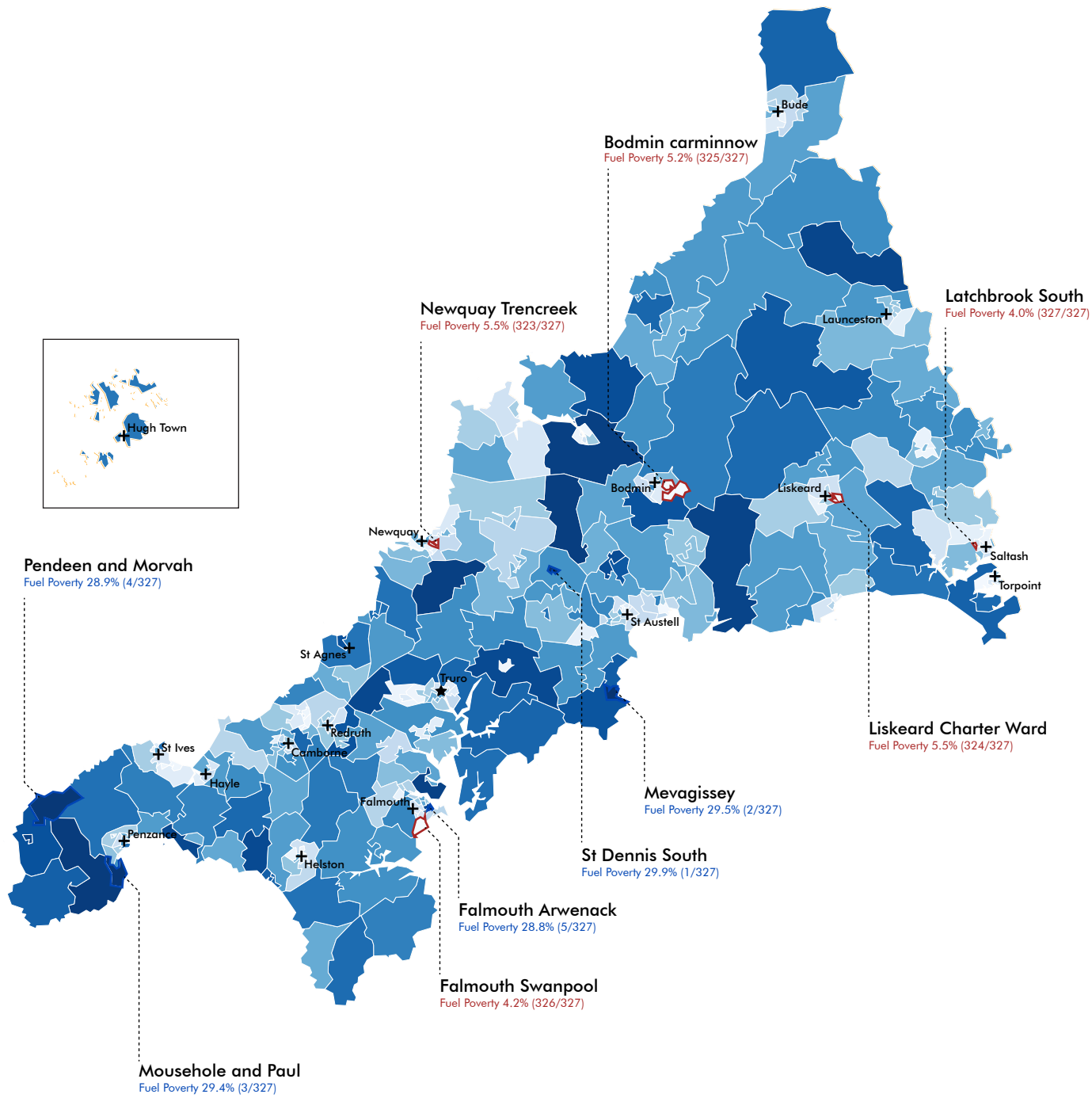

MULTIPLE DEPRIVATION IN CORNWALL PER LSOA AREA

- Greatest Percentage of Households with Multiple Deprivation
- ↓
- Lowest Percentage of Households with Multiple Deprivation
- Top 5 LSOA's with Highest Percentage of Fuel Poverty
- Bottom 5 LSOA's with Lowest Percentage of Fuel Poverty
- + Major Town
- ★ Administrative Centre

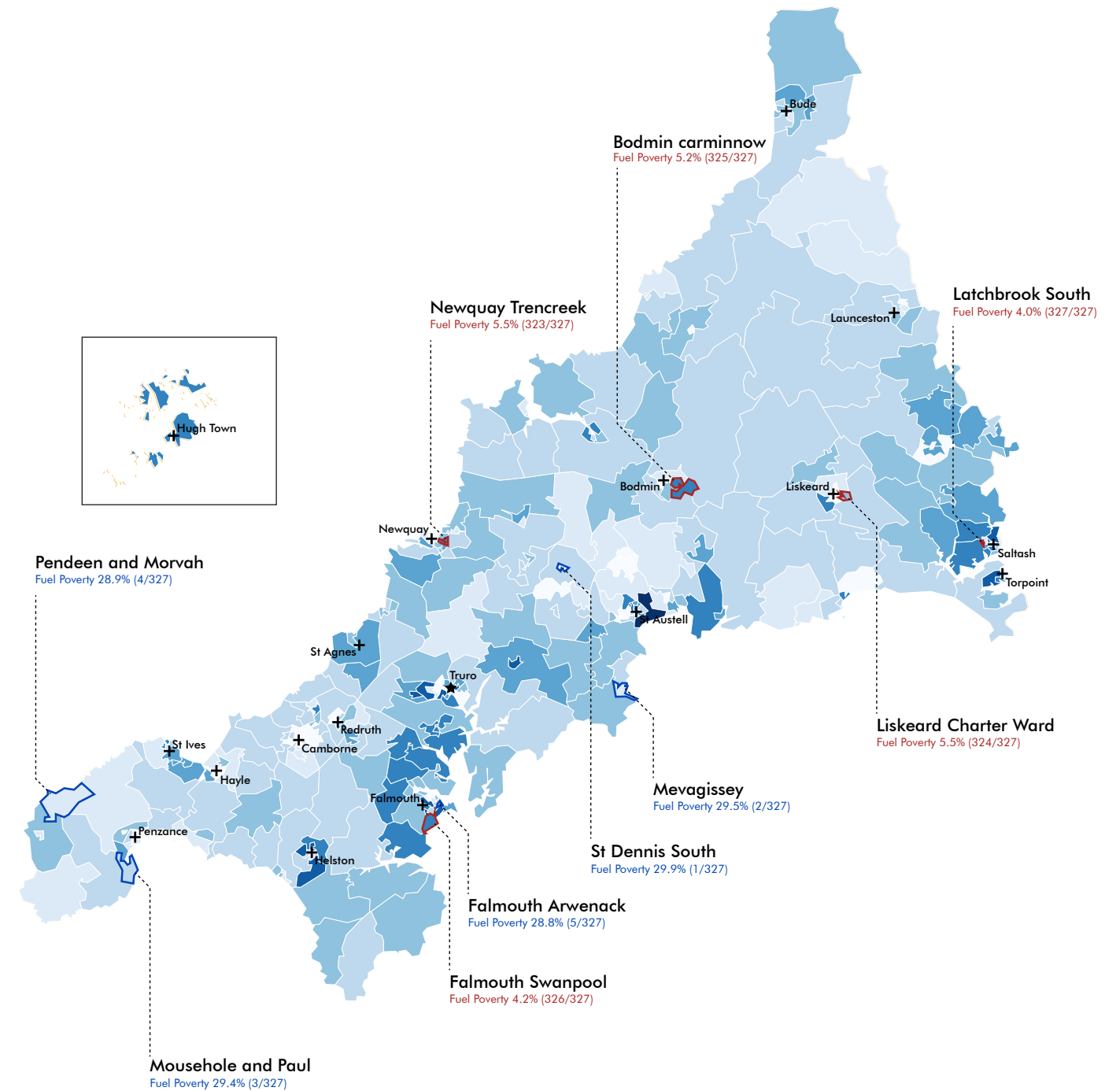

FUEL POVERTY IN AREAS NOT CONNECTED TO THE GAS GRID

- Greatest Percentage of Households in Fuel Poverty
- ↓
- Lowest Percentage of Households in Fuel Poverty
- Top 5 LSOA's with Highest Percentage of Fuel Poverty
- Bottom 5 LSOA's with Lowest Percentage of Fuel Poverty
- + Major Town
- ★ Administrative Centre

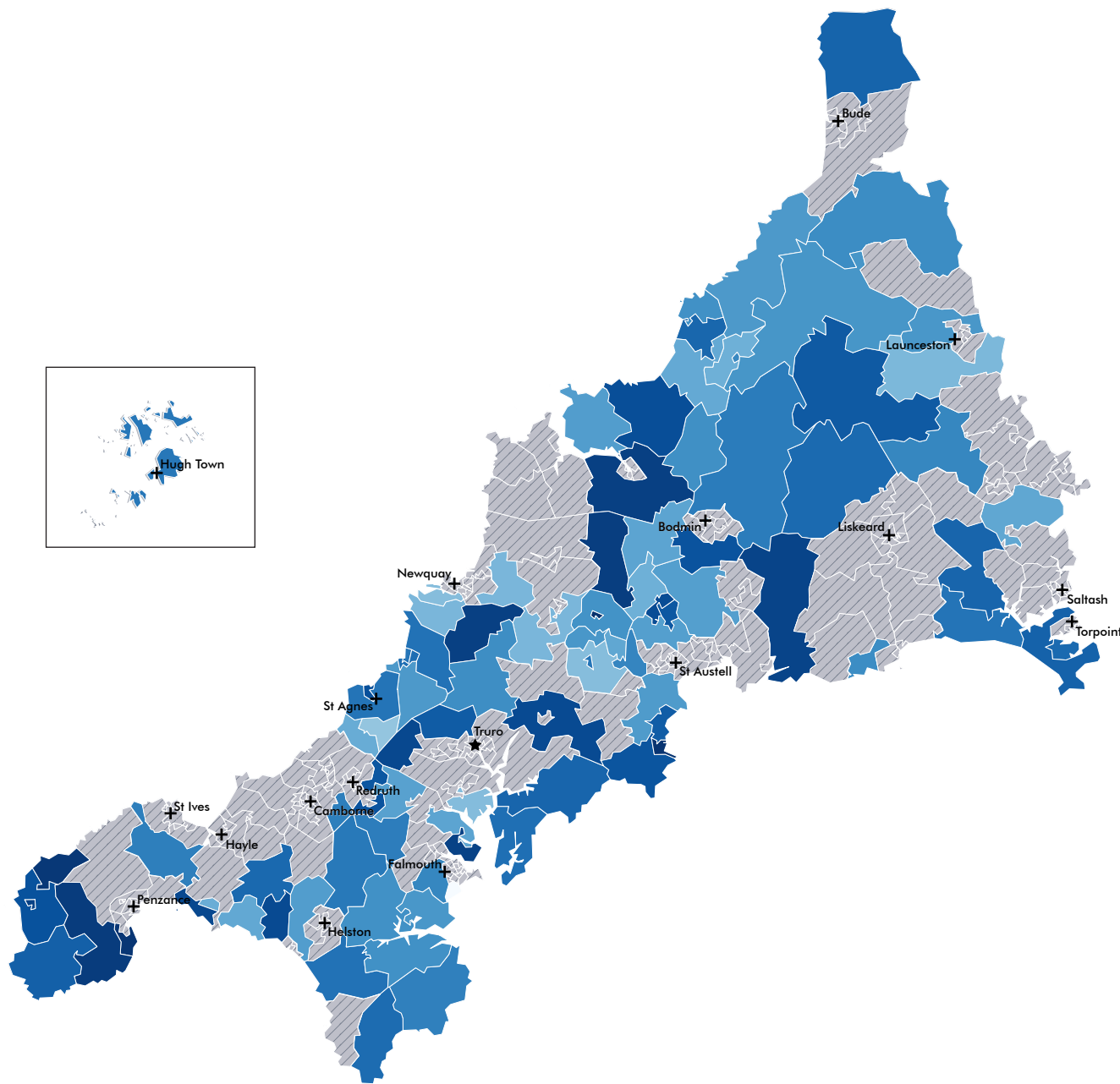

DATA MAPPING CORNWALL

FINDINGS (AND SOLUTIONS?)

Common housing typologies for fuel poor and non-fuel poor household appear to be semi-detached and terrace houses. This is typical across most areas in Cornwall and the UK in general. There is only a slight rise in the number of detached houses in the best performing LSOAs, which makes Cornwall an exception to the UK Government hypothesis that detached housing is at most at risk of falling into fuel poverty. The data states the average age group in the most fuel poor areas is 40-50 which does not correlate with the hypothesis that the elderly are the most affected by fuel poverty.

The least fuel poor housing stock is associated with EPC ratings above the national average. Typically, the most fuel poor housing stock achieves an EPC rating of at least E, which is the UK average.

The average annual cost was £1,580.80 for electric, £553.28 for oil and £444.60 for gas. The greatest disparity between the best and worst performing LSOAs comes from the difference in annual bills which is often determined by connection to the gas grid.

One solution would be to integrate a decentralised smart grid in the region, giving greater empowerment for customers to control their own usage and costs. Renewable technologies could supply this grid, with funding from the Council, or more favourably, by the communities themselves through individual investment or cooperatives for large scale projects. This has the added benefit of retaining residents money spent on energy in the region, allowing greater investment into other infrastructure.

- Worst Performing LSOA's
- Best Performing LSOA's

ENERGY + POWER

SPIRAL DIAGRAM OVERLAYING THE WORST AND BEST PERFORMING LSOAS BY HOUSING TYPOLOGIES

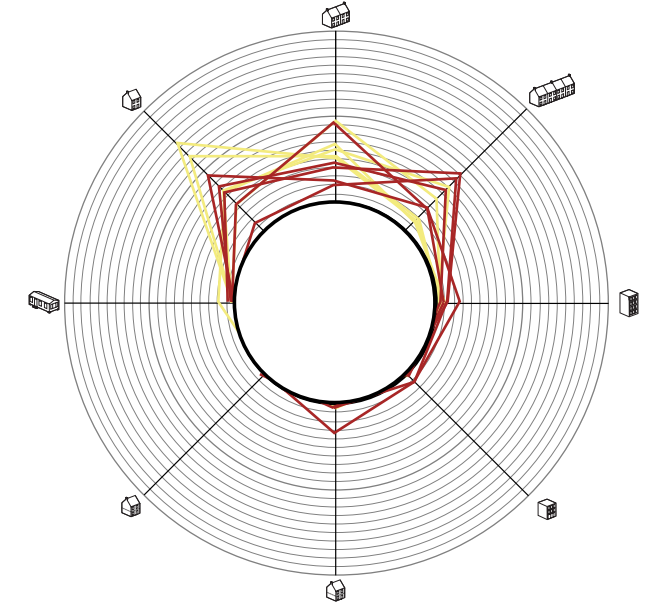

SPIRAL DIAGRAM SHOWING ENERGY EFFICIENCY RATING BY PERCENTAGE (%)

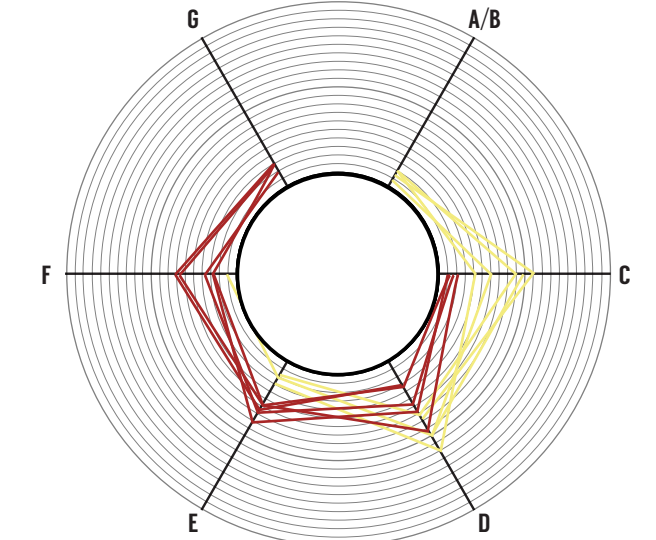

SPIRAL DIAGRAM SHOWING DIFFERENT HOUSING HEATING SYSTEMS BY PERCENTAGE (%)

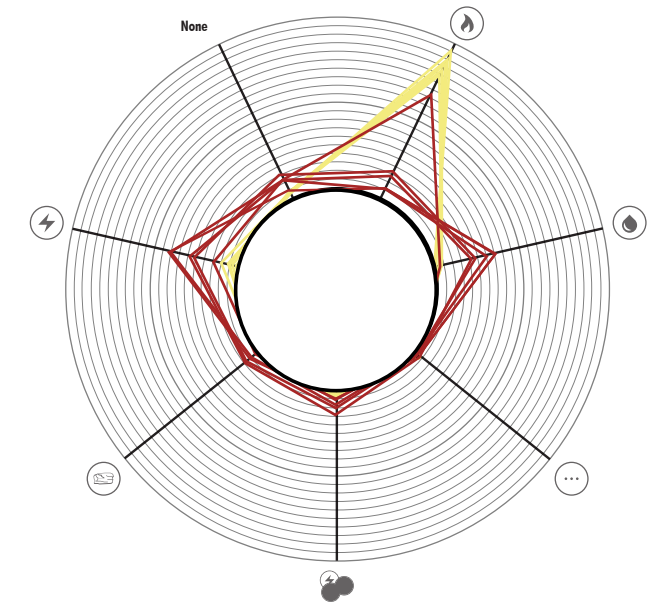

H E A L T H

+

L I F E S T Y L E

HEALTH & LIFESTYLE

The World Health Organization's definition of health is "a state of complete physical, mental and social well-being and not merely the absence of disease or infirmity".

The aim of our research was to investigate health and lifestyle in Cornwall with a view to understanding the operation and performance of space and infrastructure. Our methodology focusses on the spatial mapping of existing infrastructures based on data available in the public realm.

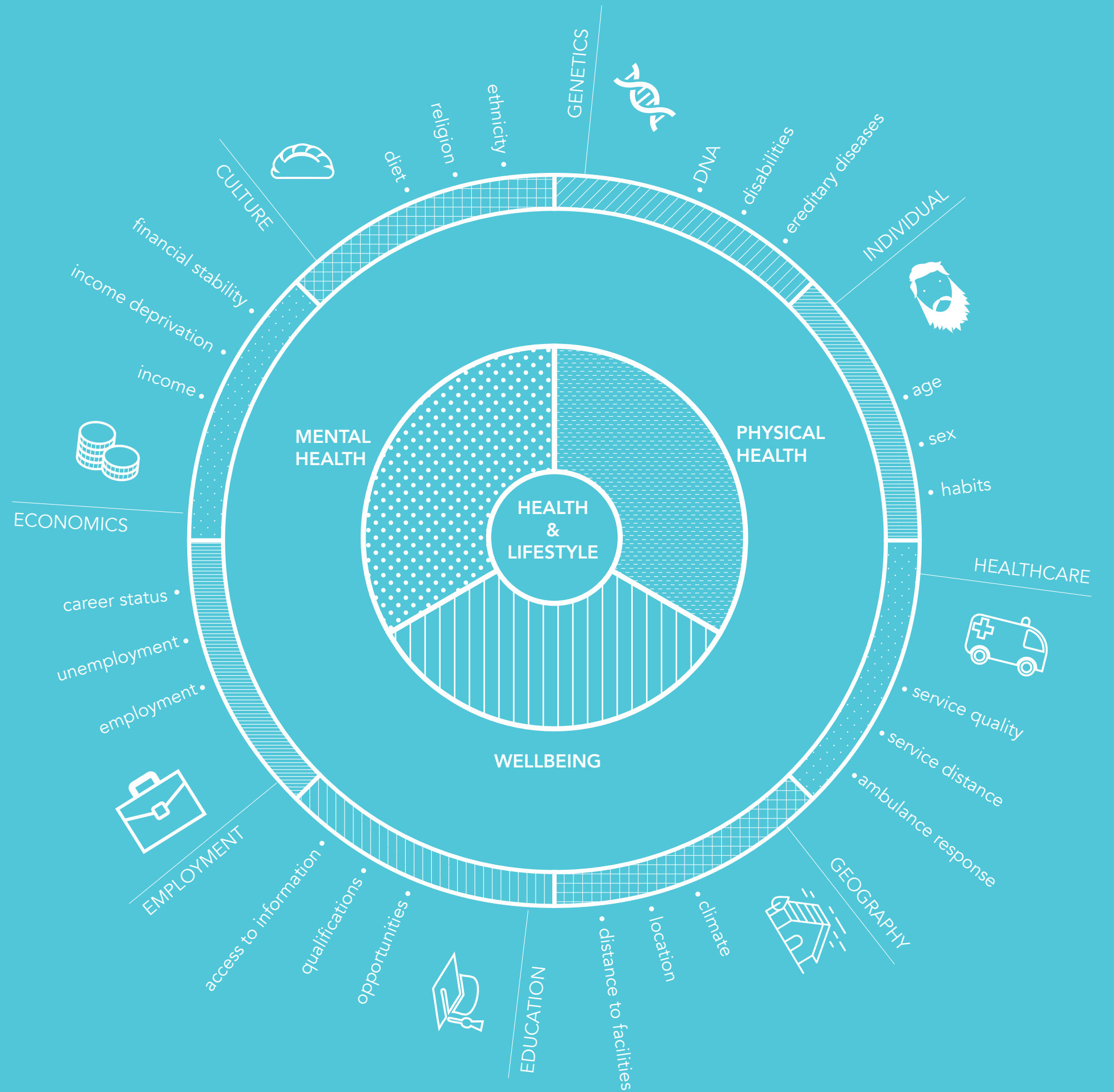

NETWORK OF HEALTH

The following diagram shows how health infrastructure is set up to respond to different incidents. From this diagram you can see which areas are under pressure and that all routes finally lead to hospital.

Each of these areas have been investigated in more detail within the atlas.

- - Accident
- - Specialist Accident
- - Non Emergency
- - Hospital

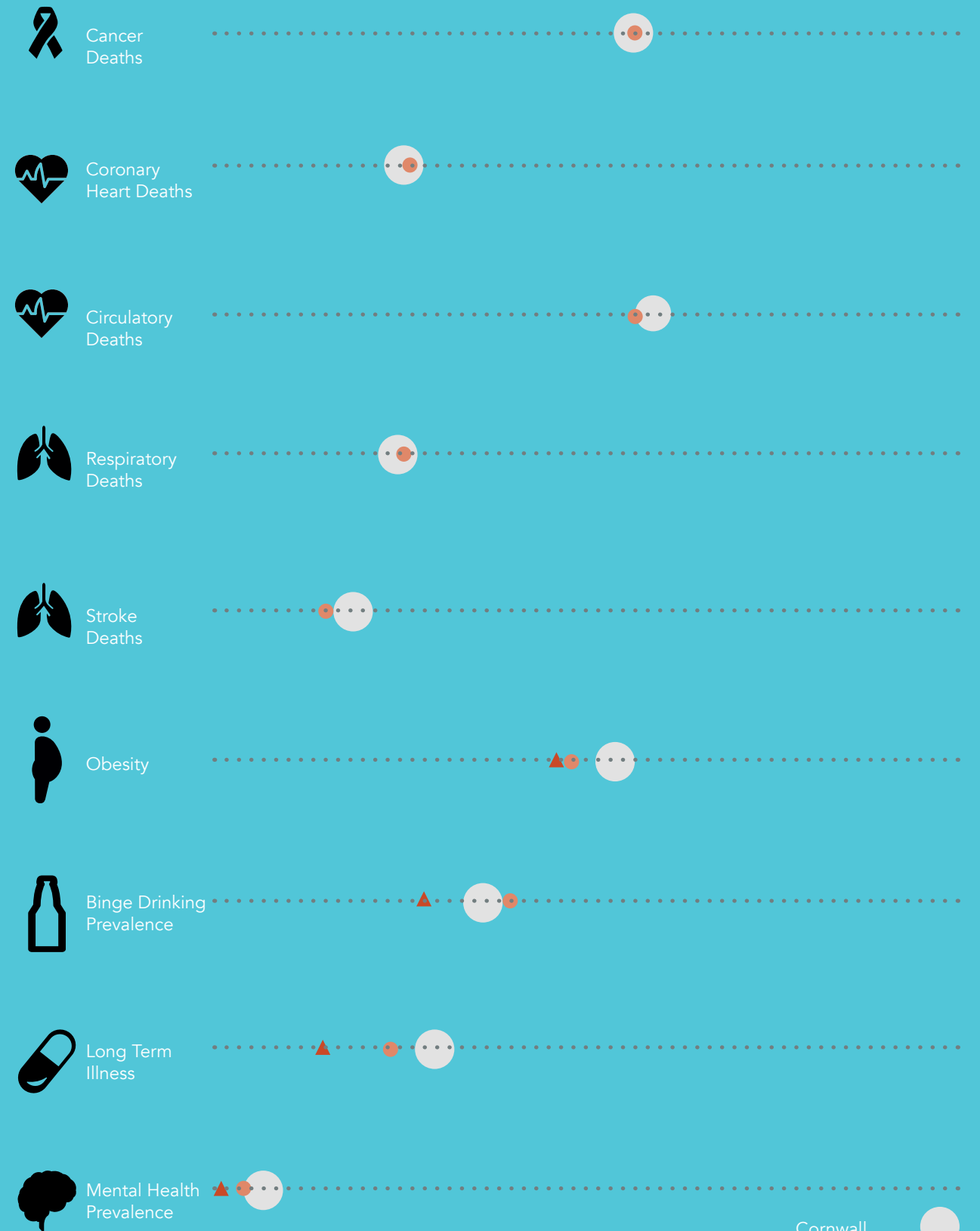

- Cornwall ●
- Isles of Scilly ▲
- England ●

SPORT INFRASTRUCTURE & OBESITY

This map overlays existing sport infrastructure and the areas identified as critical for high rates of adult and child obesity. It identifies possible areas in which the number or the variety of facilities could be improved to tackle the obesity. Potential sites are North Cornwall and the China Clay district.

The proportion of facilities by type is also shown. Some activities are more attractive and accessible than others depending on the age group of the population or on their price range. For example, the dataset shows that in Cornwall there are only 70 sites that include a swimming pool, and only 55 of these have a training pool, approximately equivalent to the number of golf sites in the area. This raises further questions concerning economic accessibility.

MAP KEY

| | |
|---------------------------|--------------------|
| ● Outdoor/Indoor | ● 3-6 facilities |
| ● Indoor | ● 6-9 facilities |
| ○ Outdoor | ● 9-12 facilities |
| — Cycle routes | ● 12-15 facilities |
| ▨ Critical obesity 25-30% | |
| ▨ Obesity 23-25% | |

Sport England, Active Places Power Database, www.gps-routes.co.uk

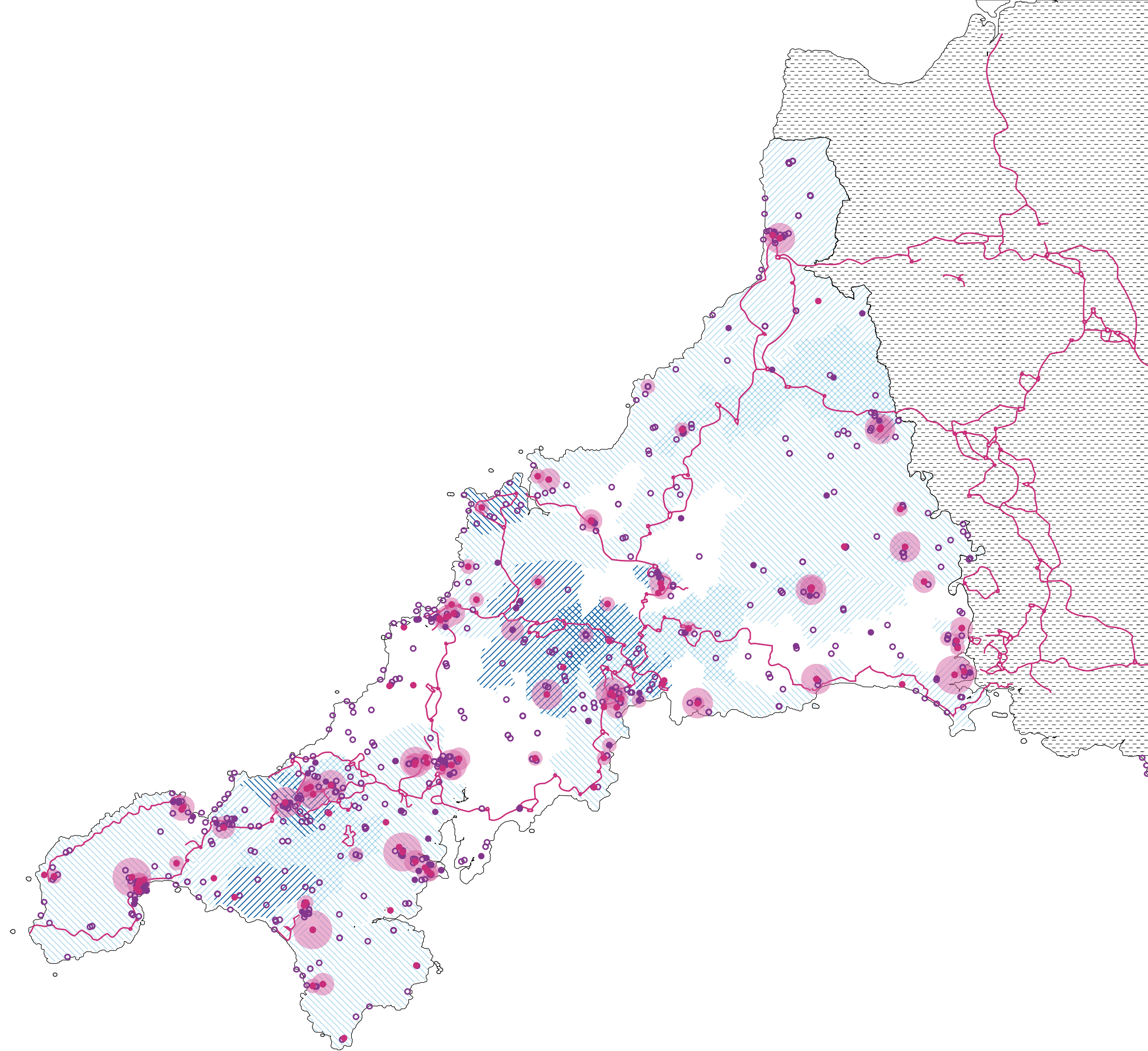
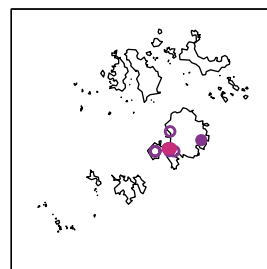

FAST FOOD & DEPRIVATION

- Most deprived LSOAs for income
- Fastfood density in a 5km radius

BURGER KING
DOMINO'S
KFC
MC DONALD'S
PIZZA HUT
SUBWAY

- Outdoor/Indoor Sports Infrastructure
- Indoor Sports Infrastructure
- Outdoor Sports Infrastructure
- Organic, gourmet and kosher food
- Grocers, farm shops and pick your own
- Independent supermarkets
- Supermarket chains

reference: EDINA Digimap Ordnance Survey Service, Sport England, Active Places Power Database, www.gps-routes.co.uk

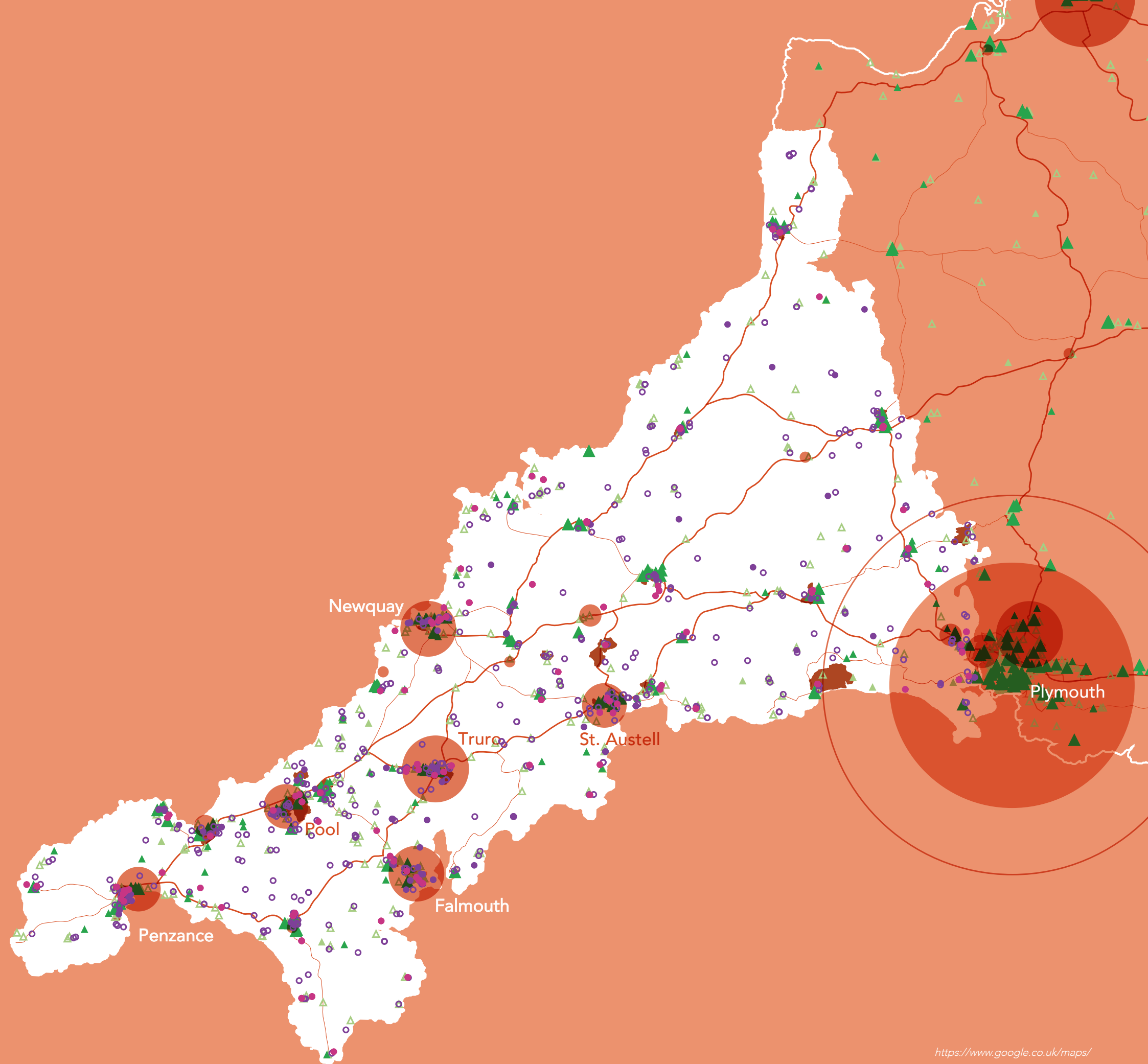
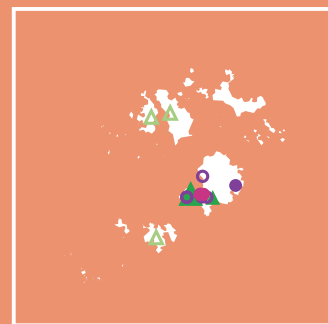

<https://www.google.co.uk/maps/>

SOCIO-ECONOMIC STATUS & ADULT OBESITY

This map compares areas with a higher percentage of people in lower socio-economic groups and critical adult obesity rates. The data shown is the National Socio-Economic Classification combined with the rates of people whose occupation is classified as Lower Supervisory, Semi-Routine and Routine.

The map appears to show a consistent overlap between the two factors, that could be due the lower wages or less flexibility in the management of working hours. In additional work we overlaid obesity rates with different kinds of occupation, which appeared to show a relationship between the two factors.

Within the time constraints of this study no data could be accessed for the Isles of Scilly

MAP KEY

■ 35.7-41.7 ▨ Adult obesity >25%
■ 41.7-49.7

<http://www.localhealth.org.uk>, <https://www.nomisweb.co.uk>

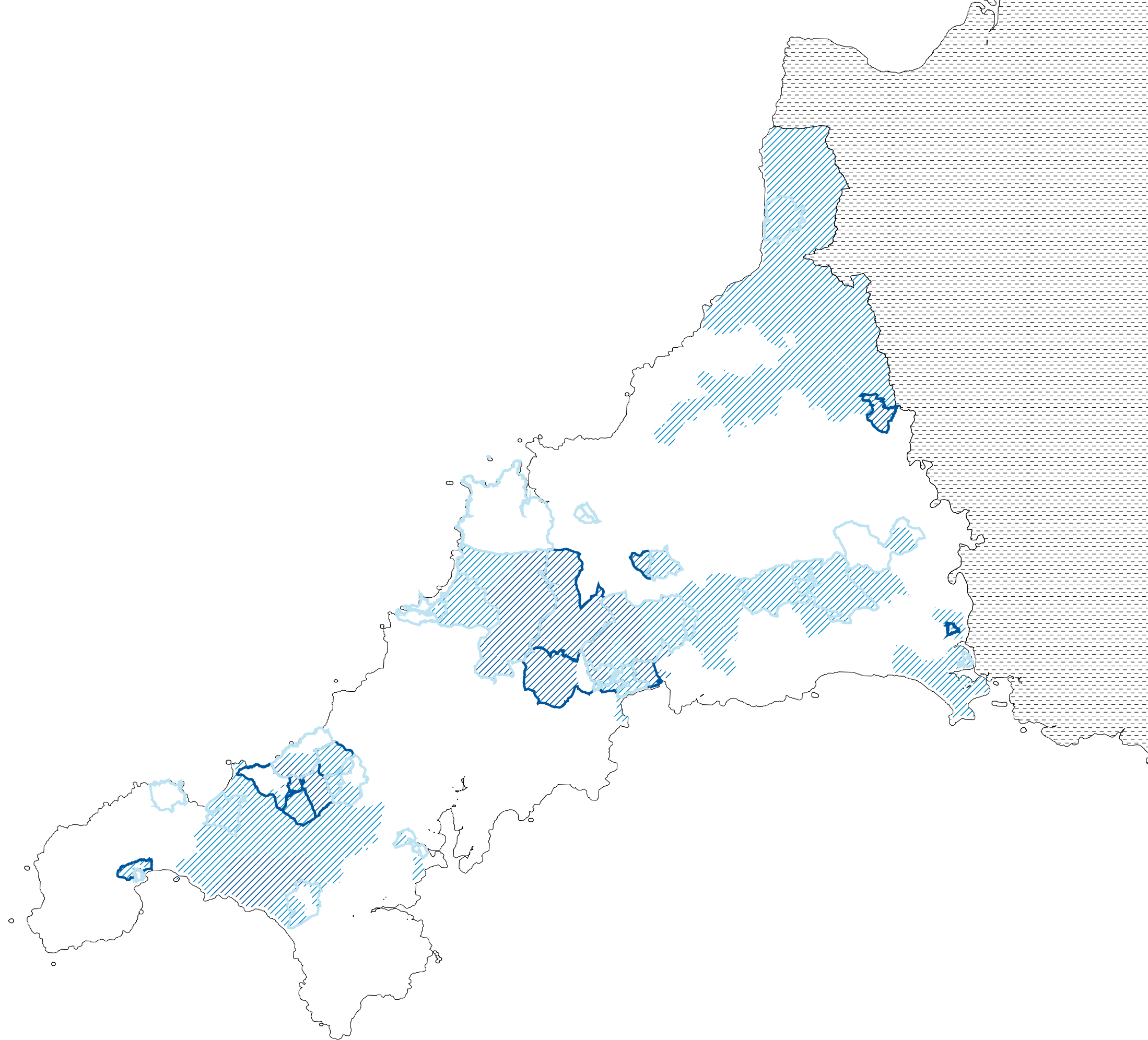

5 10 20 30km



ANTI-DEPRESSANTS/ LOWER SOCIO-ECONOMIC GROUPS

No obvious correlations between anti-depressant prescriptions and specific jobs could be found using the data sets available. However, by investigating lower socio-economic groups and the effect low income on mental health, an indicative correlation can be seen.

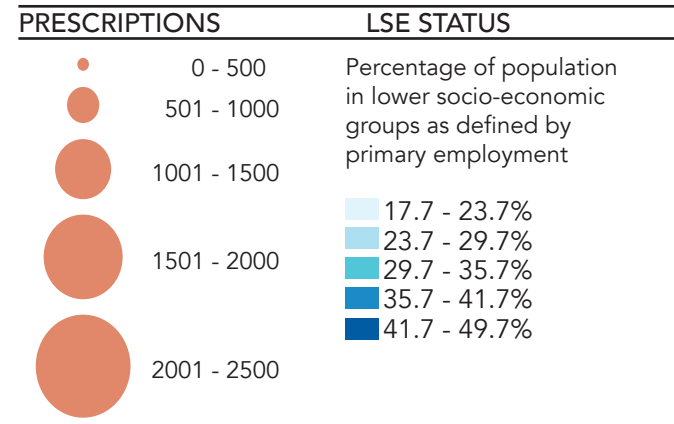

<https://data.gov.uk/dataset/prescribing-by-gp-practice-presentation-level/>
<https://www.nomisweb.co.uk/>

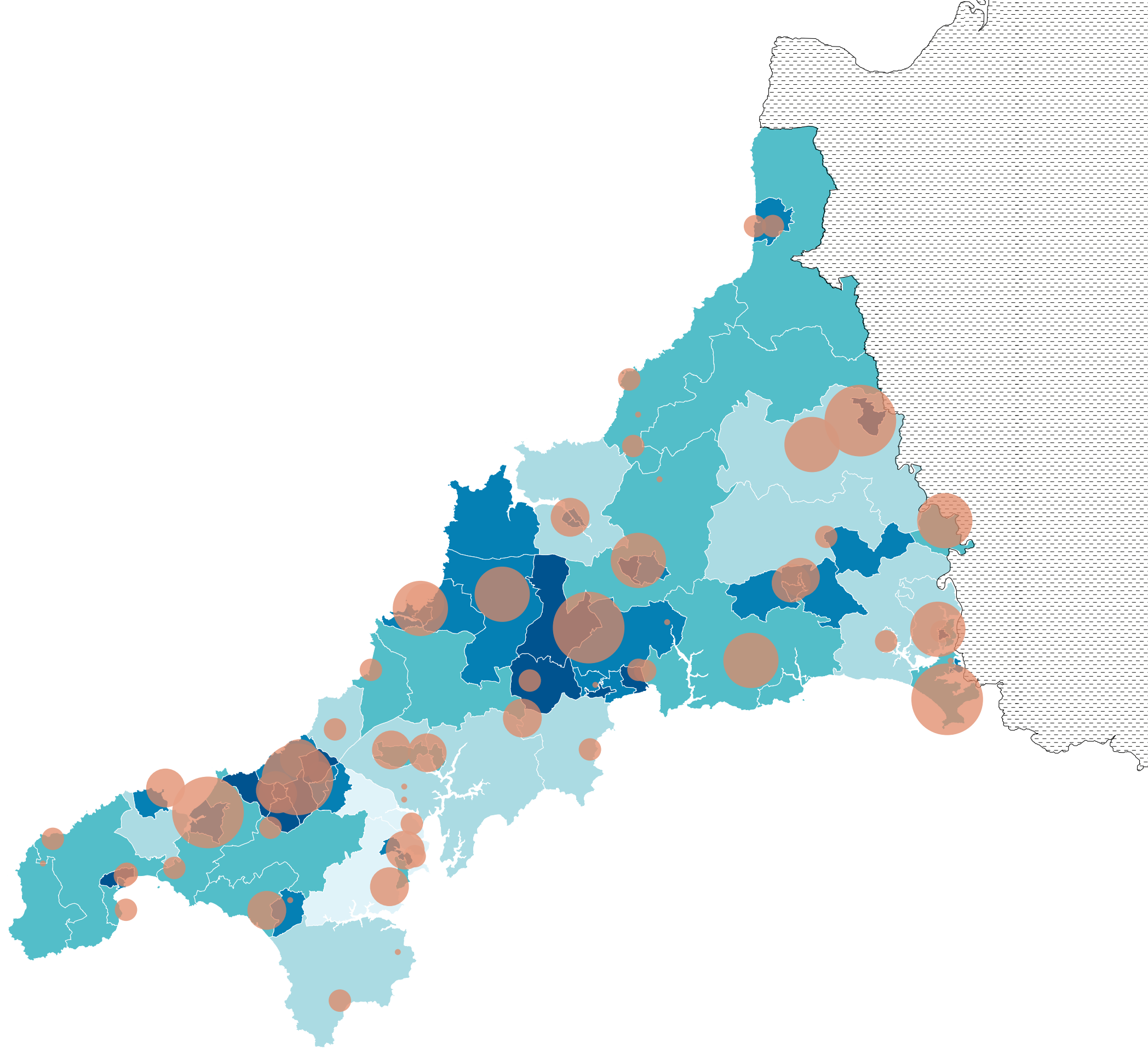
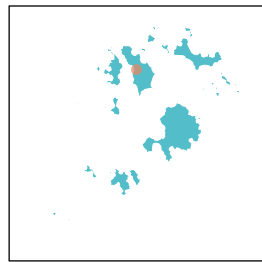

ANTI-DEPRESSANTS & POPULATION

Using GP public data, the diagram displays average figures for 2015 relating to anti-depressant prescriptions in high and low season.

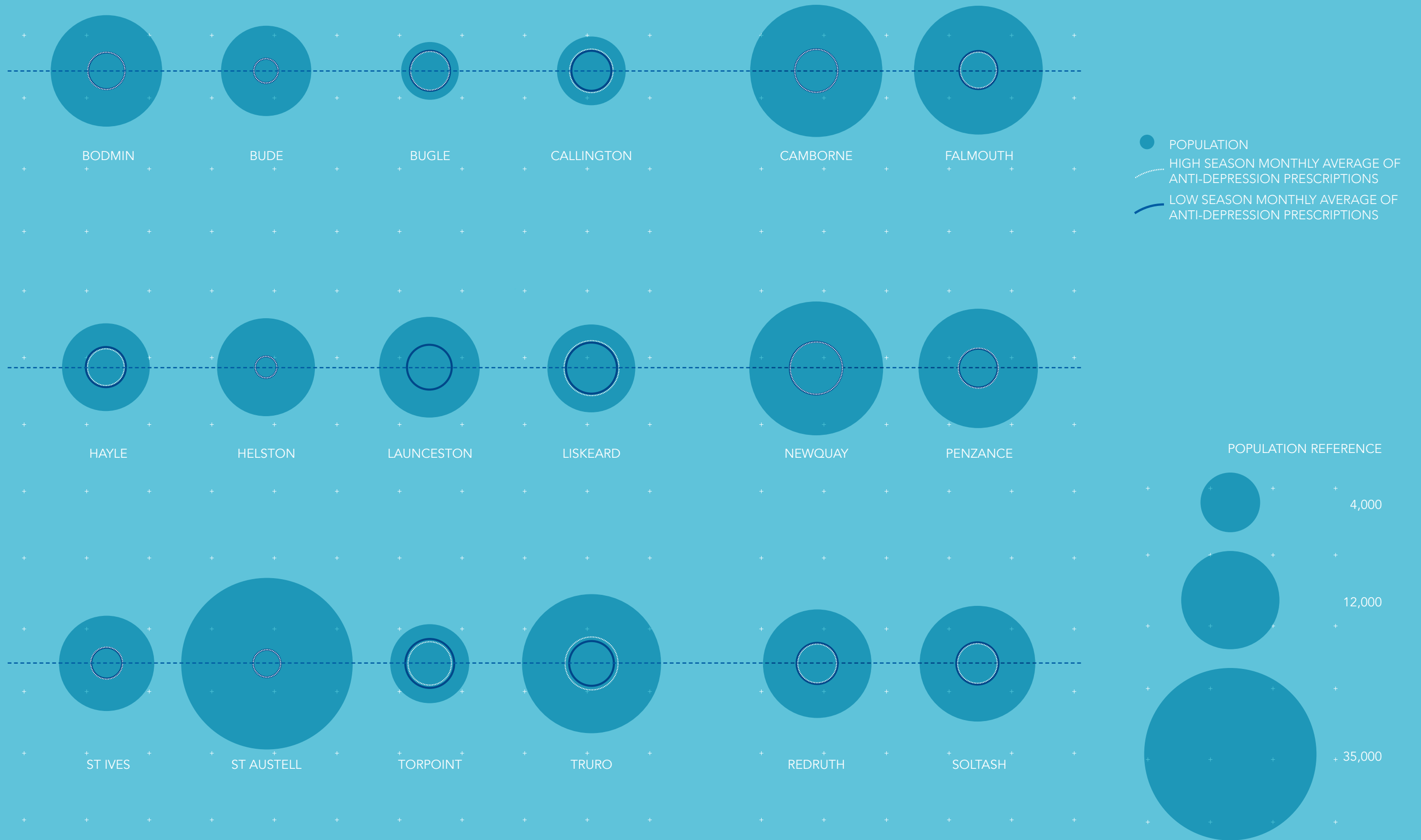

SUICIDE ATTEMPT CALL OUTS & MENTAL HEALTH SERVICES

This mapping shows the mental health facilities plotted against suicide attempt call outs as an average for 2010. The highest rates of suicide are covered well by mental health facilities. One exception to this is Newquay, which seems to have a high rate of call outs but appears to lack the facilities to cope with depression and mental health problems.

NUMBER OF SUICIDE ATTEMPT RELATED CALL OUTS

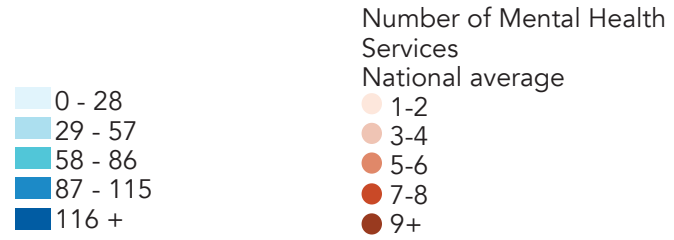

<https://www.ambulanceresponsetimes.co.uk>
<https://www.totallycommunications.com>

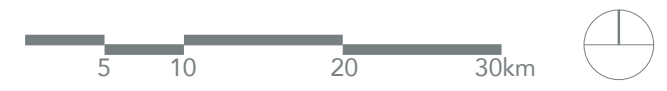
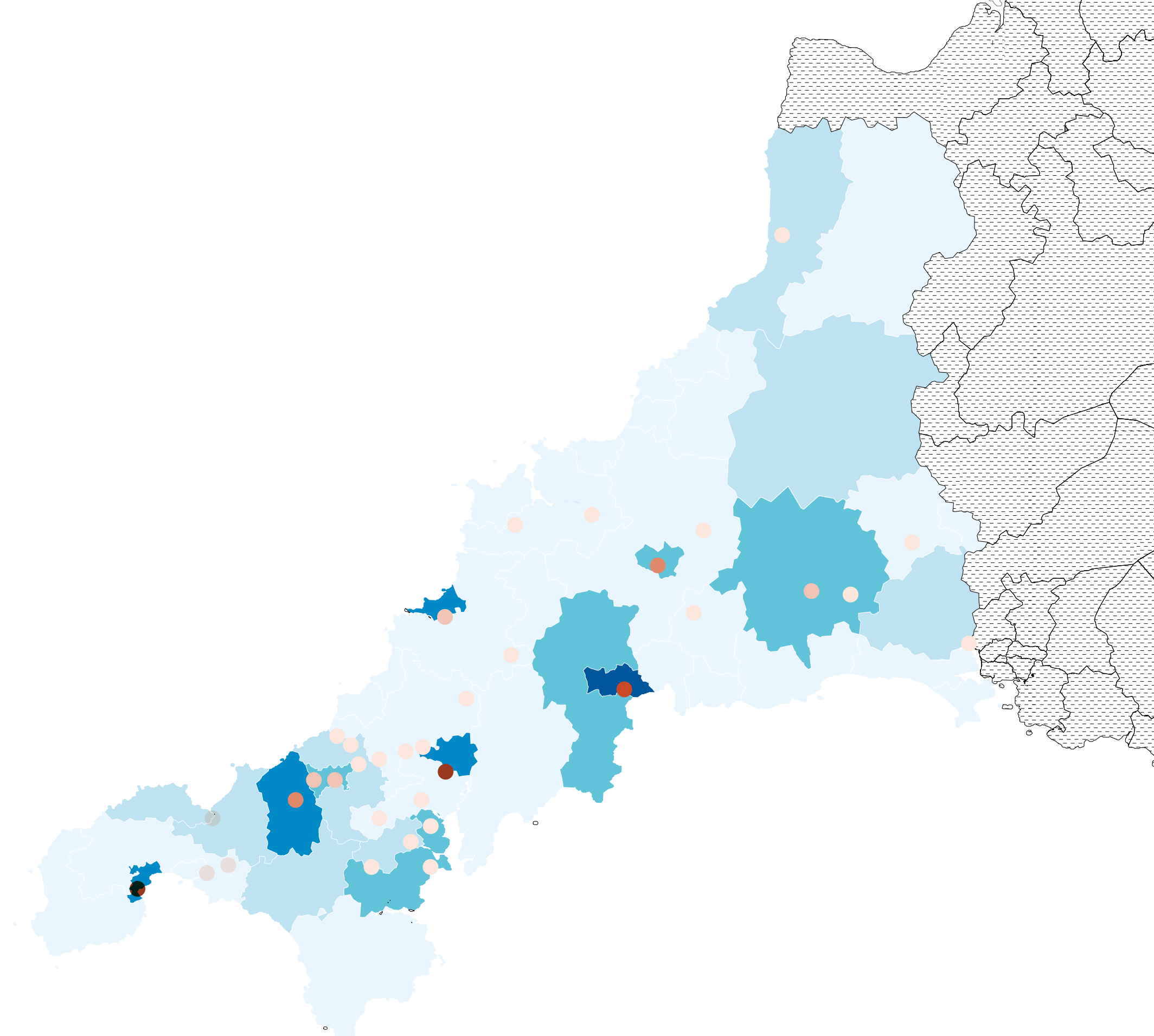
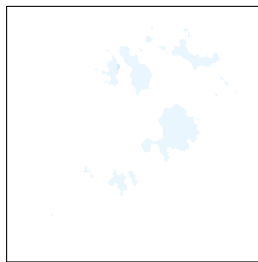

CARE FACILITIES

This map represents response by need. There is not a significant sample of people with only a written care plan (0.1% of the sample). There is a balanced representation of people who have long standing health or care needs and those who do not as illustrated opposite.

Within the time constraints of this study no data could be accessed for the Isles of Scilly.

Map Key

- Care Homes
- Residential Communities

Age 65 +

- 25 - 38%
- 22 - 24.9%
- 19-21.9%
- 16 - 18.9%
- 10 - 15.9%

reference: [http://ukdataexplorer.com/census/southwest/local insight 2011 Census - Communities and environment: Classification of neighbourhoods](http://ukdataexplorer.com/census/southwest/local%20insight%202011%20Census%20-%20Communities%20and%20environment/Classification%20of%20neighbourhoods)

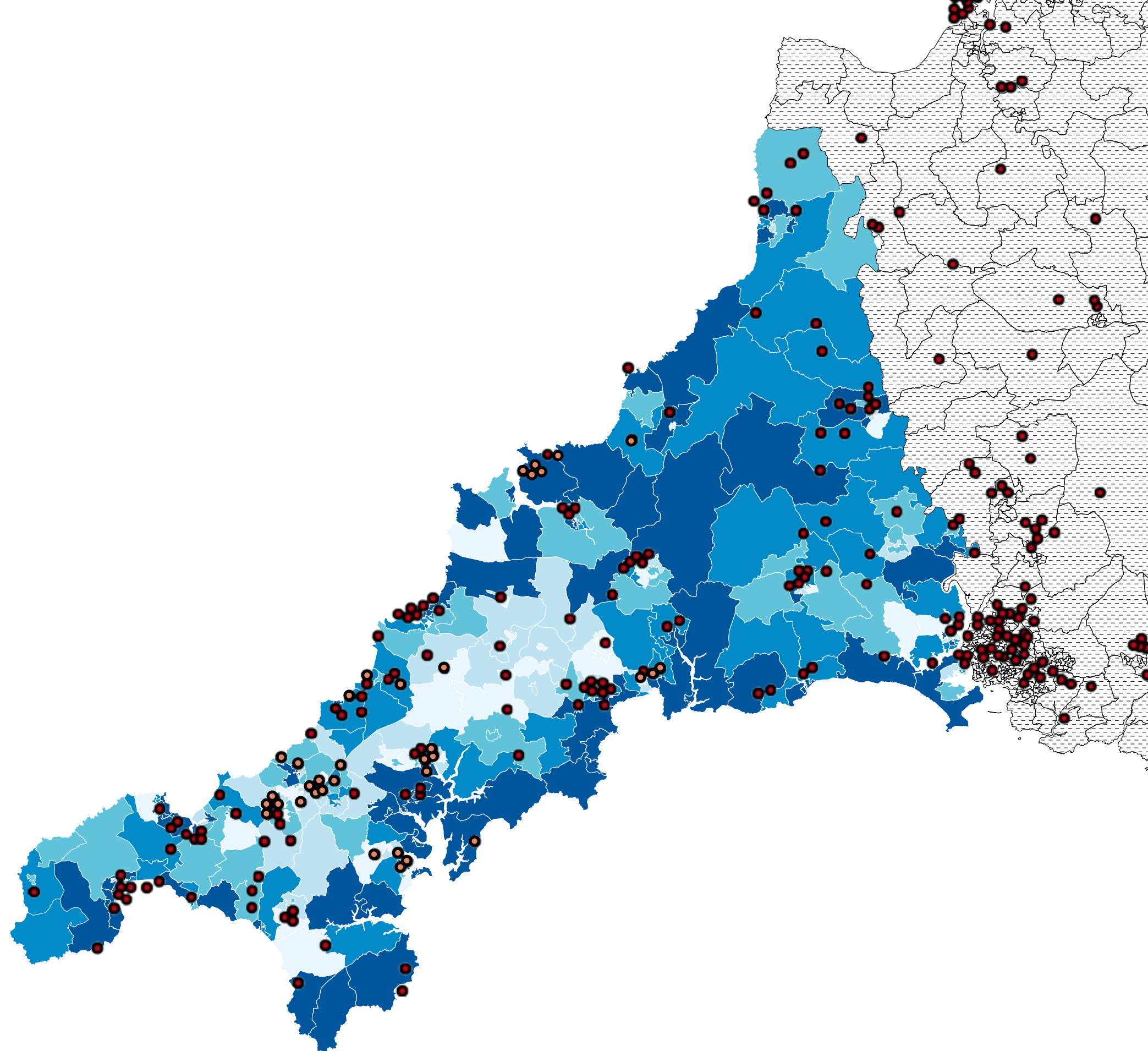

5 10 20 30km



CARE STANDARDS

There are continual and significant pressures on acute services at both Royal Cornwall and West Cornwall Hospitals and nursing homes. The pressures experienced in community hospitals (most now operating at over 95% occupancy) is above the accepted level for delivering high quality, safe patient care. As a result there appears to be a lack of high quality nursing and residential home capacity and domiciliary care in the west of Cornwall.

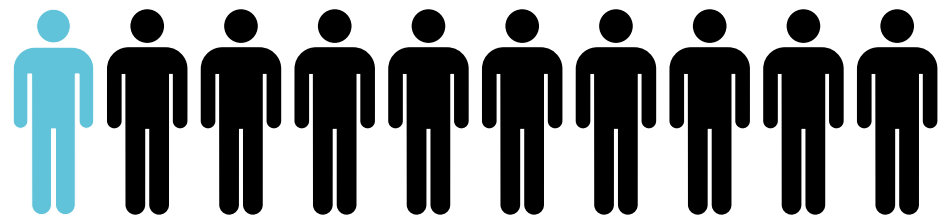

1/10 people are at risk of malnourishment in England and Wales

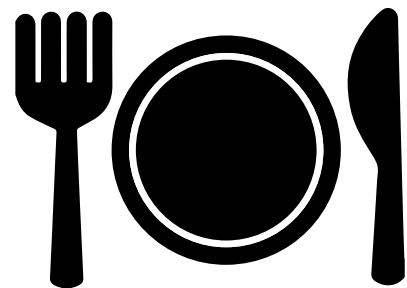

3 Million people age of 65+ suffer from malnourishment in the



Annual UK health and social care cost directly associated with malnutrition is over £13 billion

reference: <http://westcornwallhealthwatch.com/concern-over-lack-community-beds-west-cornwall>

Malnutrition according to types of Care homes

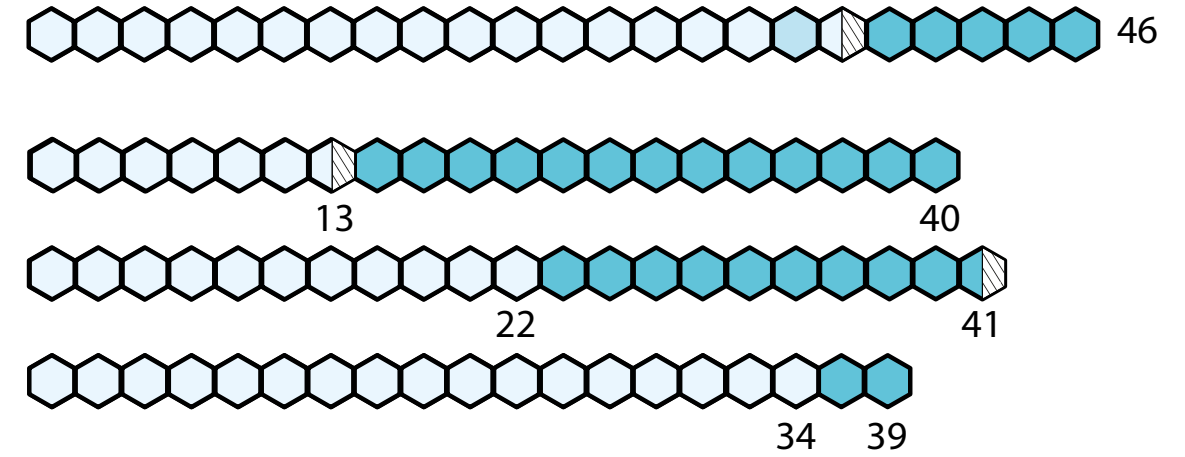

Malnutrition according to nutrition screening

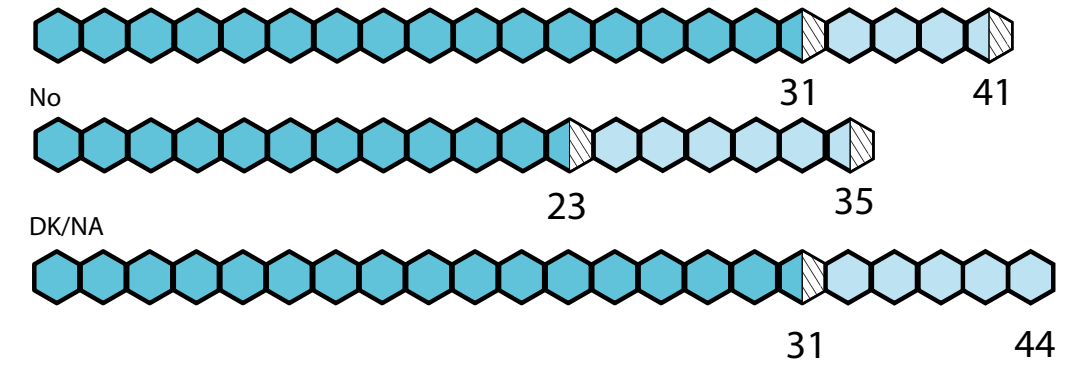

Malnutrition according to number of Care home beds

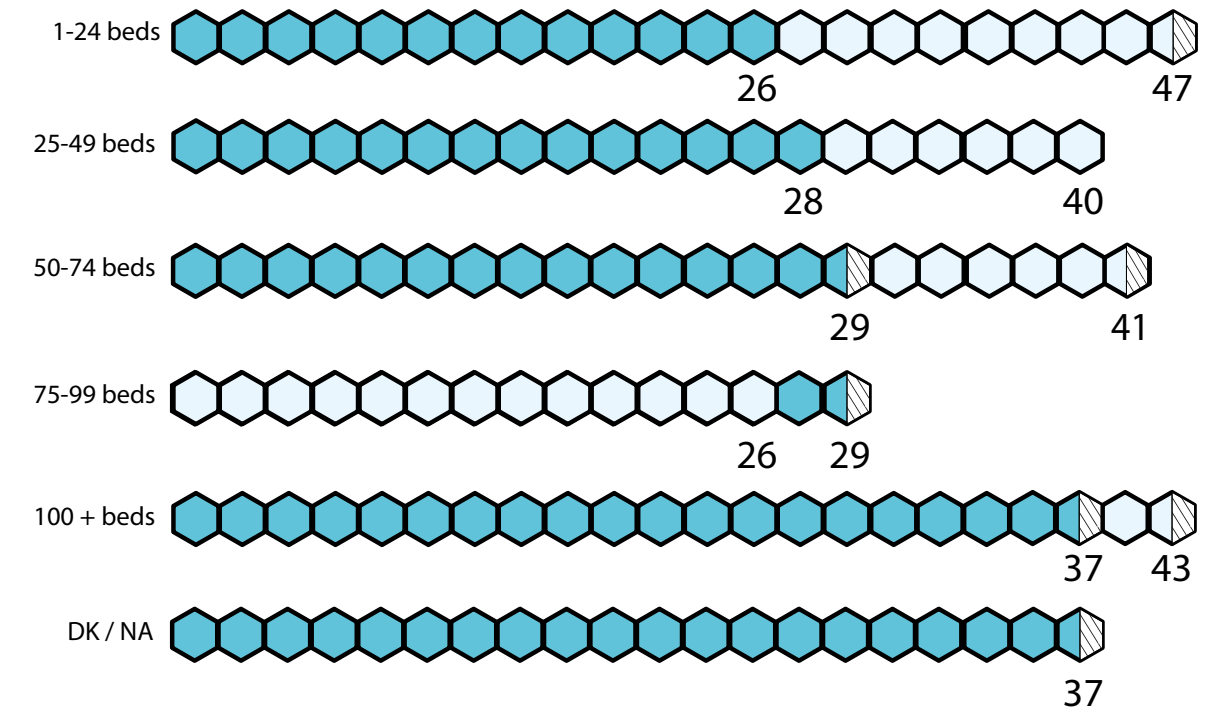

2011
2007

HEALTH CARE CONNECTIVITY

Cornwall's health services are divided up amongst three different parties; The Royal Cornwall Hospital Trust, Cornwall Partnership NHS Foundation Trust and South West Ambulance Service. This map shows the links between the Hospitals, GPs and Clinics. The following map shows the locations of each of these and how they're connected, from small GPs to their local hospitals and then to The Royal Cornwall Hospital in Truro.

The size of the circles reflects the amount of people that have registered to each of the GPs or clinics in 2016. (1mm = 1000 people) This gives a useful indication about the location of Cornwall's population and the pressure on health care facilities.

566,304 People registered in 2016

MAP KEY

- - Hospitals
- - Ambulance Station
- - GP
- - Clinic
- - Other Facility

<http://www.ambulanceresponsetimes.co.uk>
<https://www.cornwall.gov.uk>
<http://carto.com>

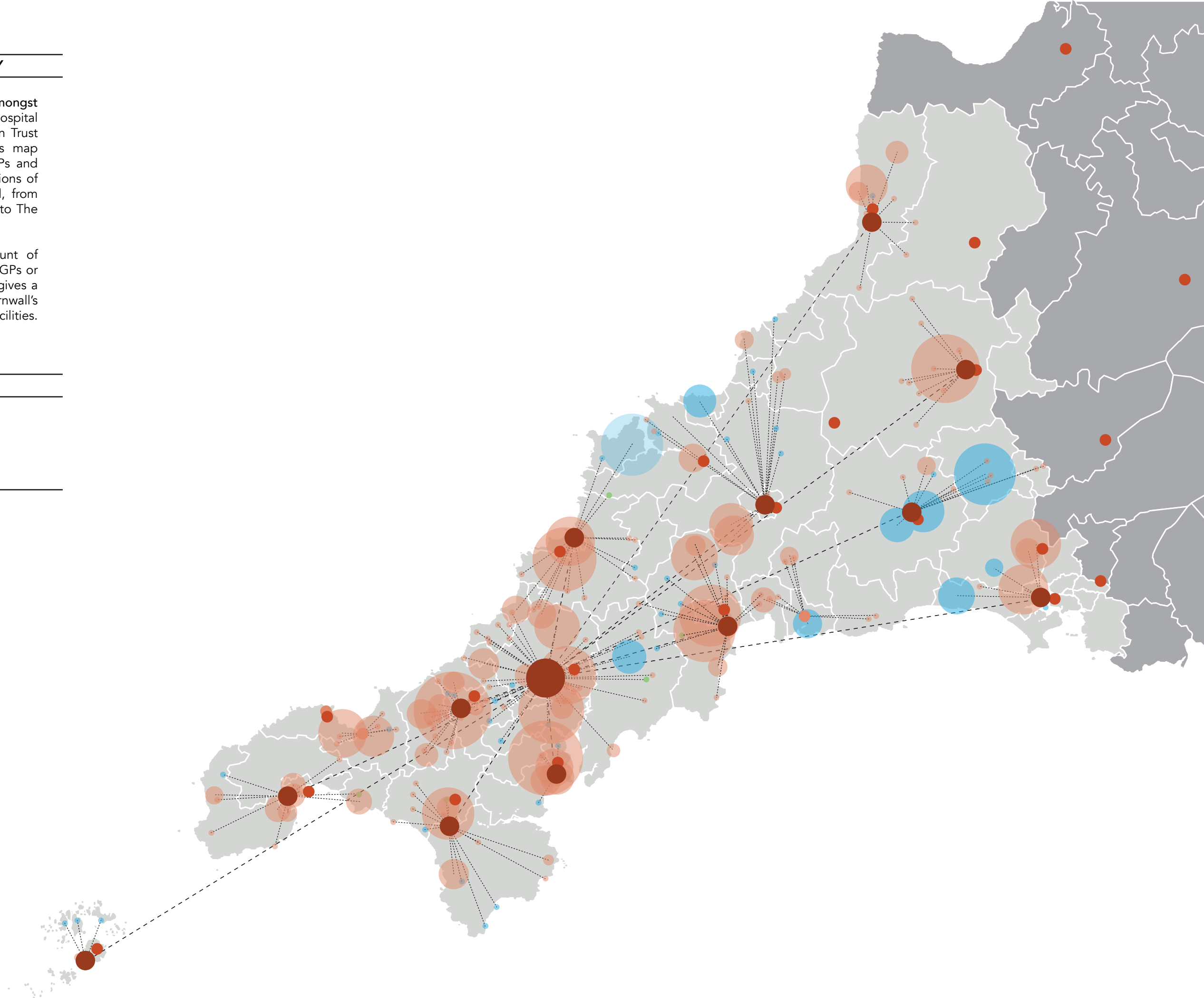

CALL-OUT COMPARISON

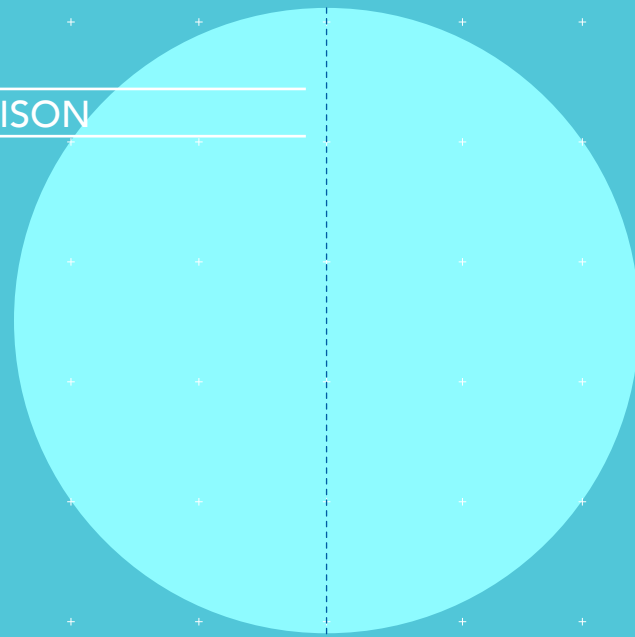

Ambulance **33,000**

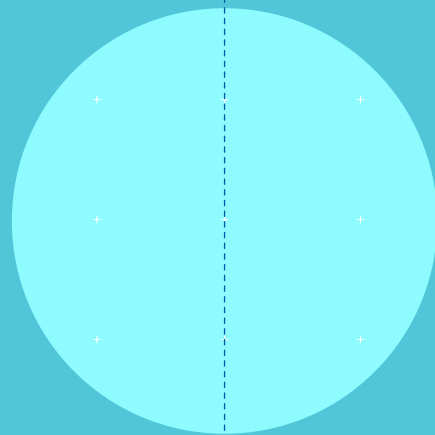

Police **22,454**

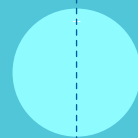

RNLI Lifeguard **6760**



Fire Brigade **5624**

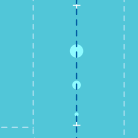

Air Ambulance **764**

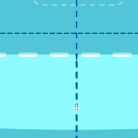

RNLI Lifeboat **461**

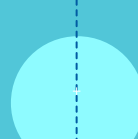

Search & Rescue **282**

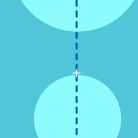

Mountain Rescue **76**

● Incidents

x10

DATA MAPPING CORNWALL

REGIONAL COMPARISONS

AIR AMBULANCE

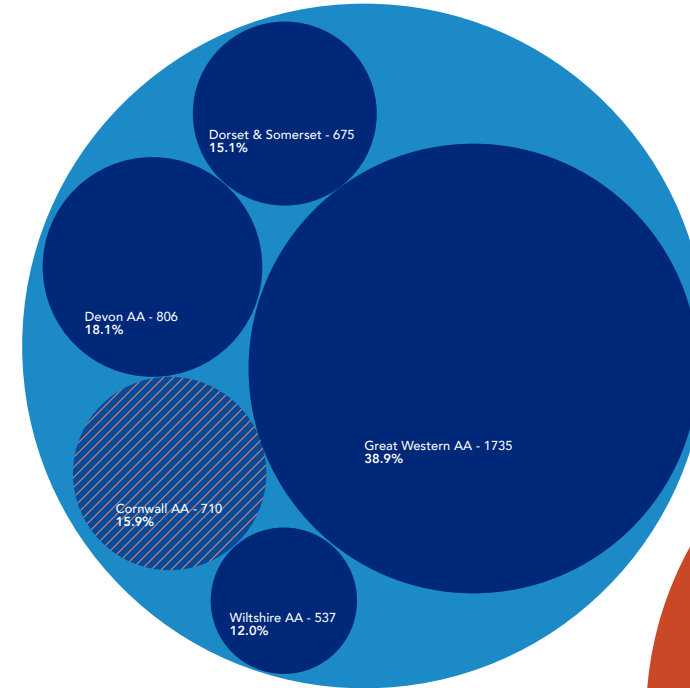

POLICE

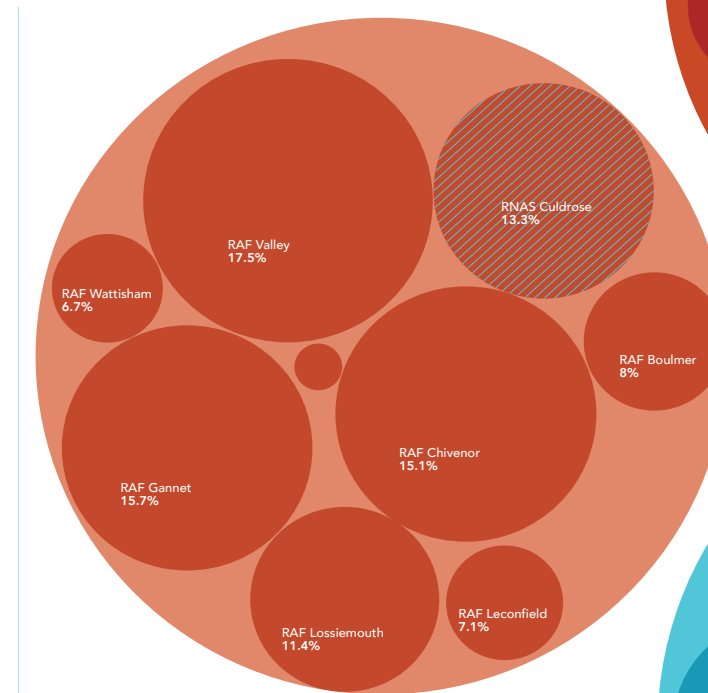
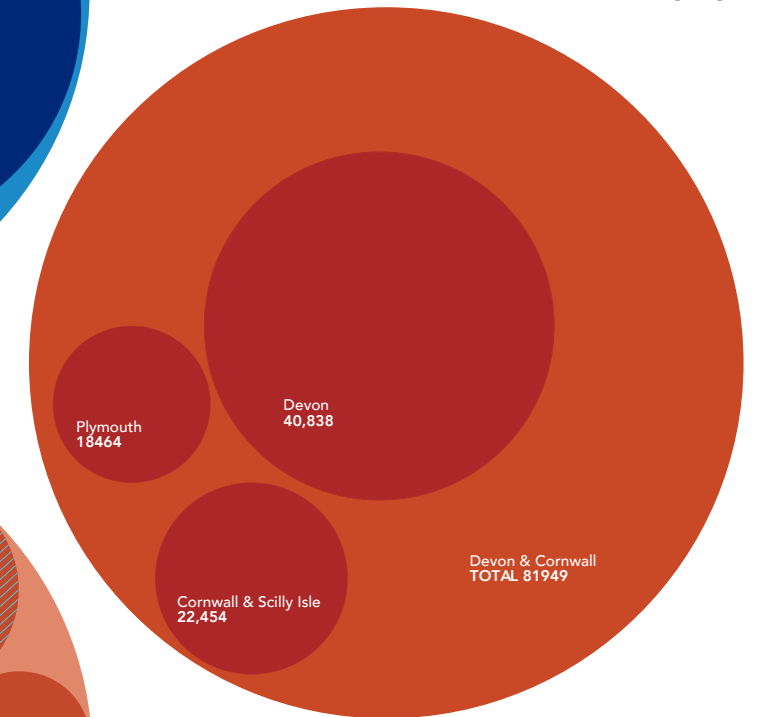

SEARCH & RESCUE

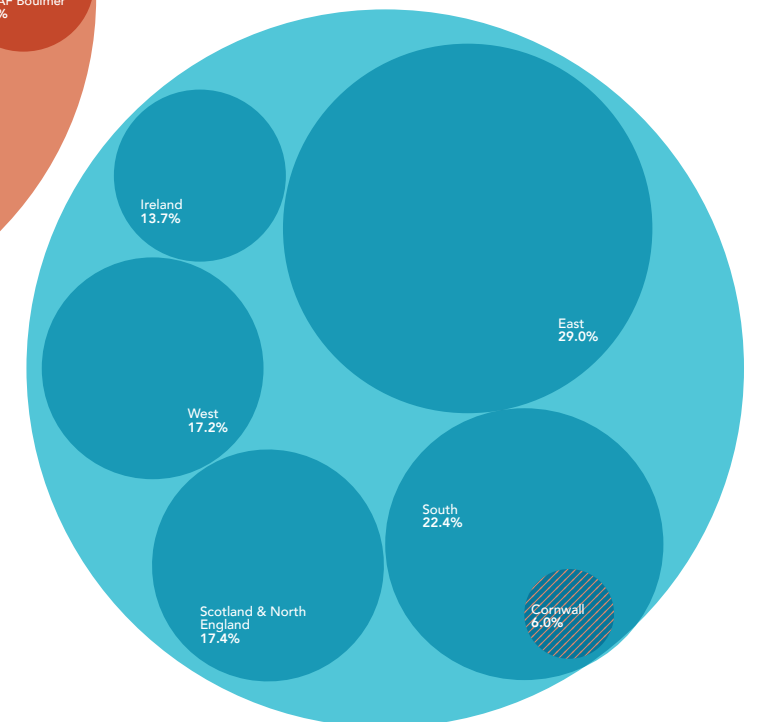

RNLI

HEALTH + LIFESTYLE

MEDIAN AMBULANCE RESPONSE TIMES BY POSTCODE IN CORNWALL

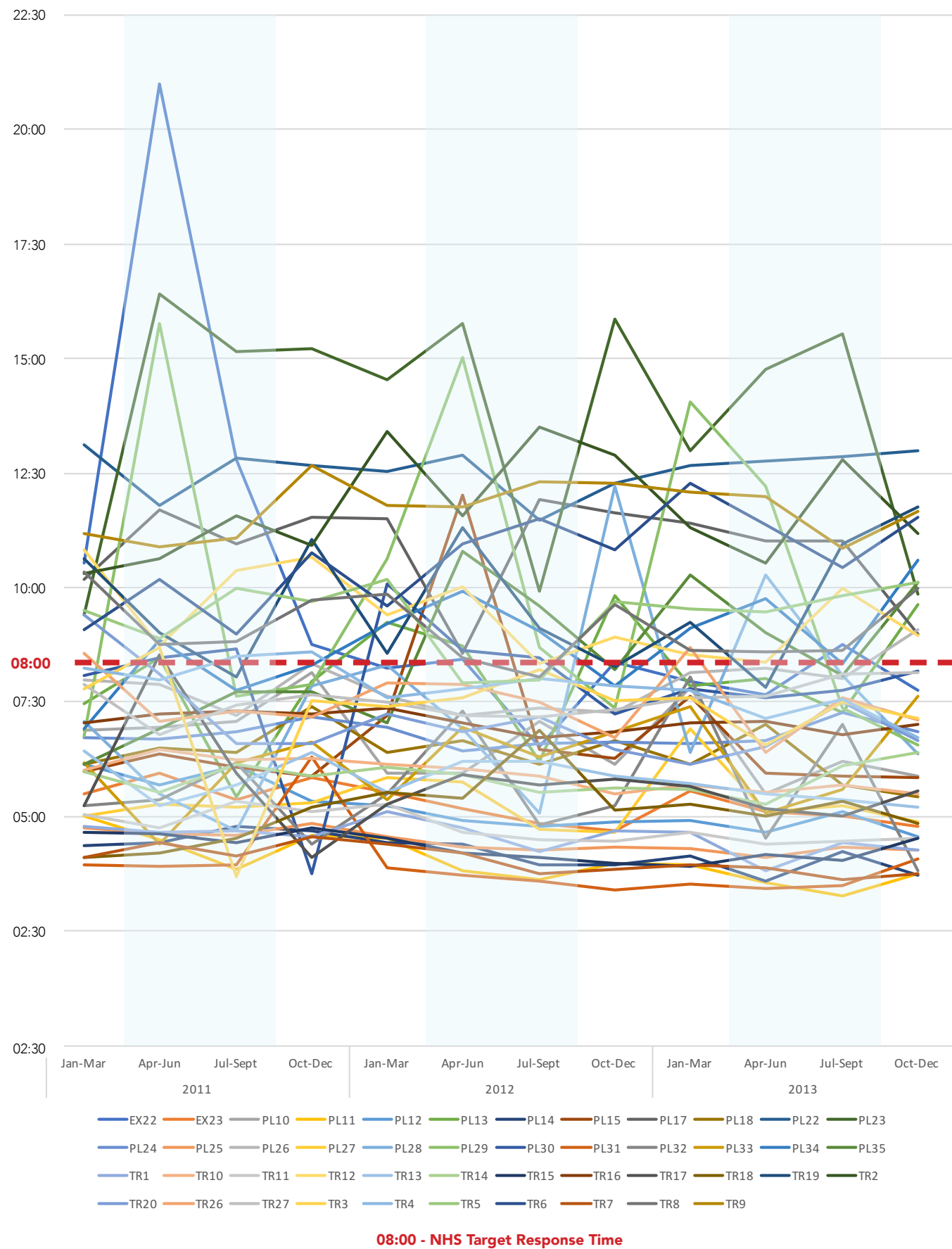

SEASONAL AMBULANCE CALL OUTS - CORNWALL & NATIONAL

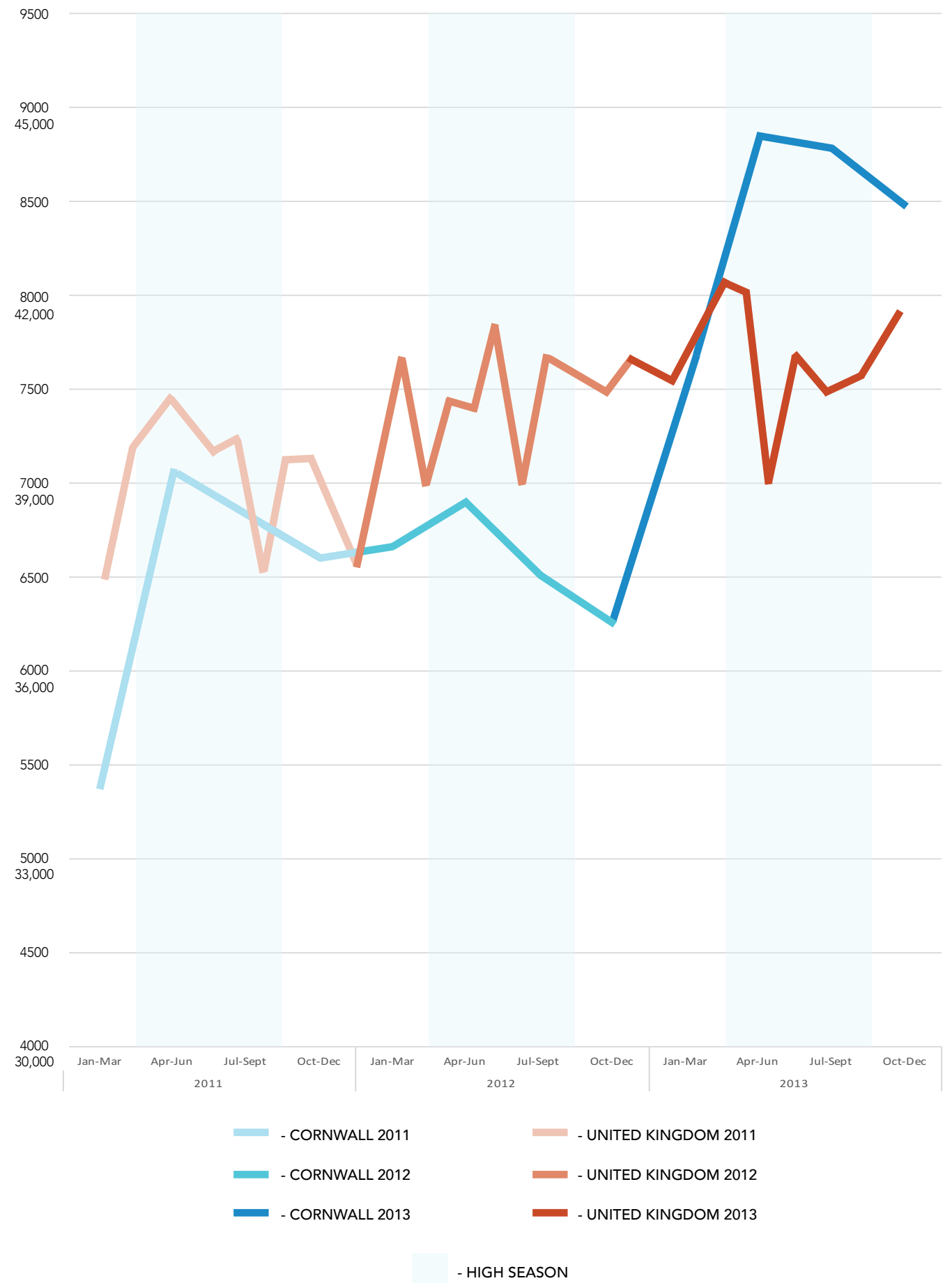

MAPPING SEASONAL PRESSURES

By overlaying maps for ambulance response times and accidents for high and low season areas the effects of seasonality can start to be recognised.

The maps have highlighted that there is a band across the middle of Cornwall (TR4, TR9, TR2, PL25 & PL26).

MAP KEY

1 Lowest response times and least amount of accidents.

| | | | |
|----|----|----|----|
| 1 | 2 | 3 | 4 |
| 5 | 6 | 7 | 8 |
| 9 | 10 | 11 | 12 |
| 13 | 14 | 15 | 16 |
| 17 | 18 | 19 | 20 |
| 21 | 22 | 23 | 24 |

24 Highest response times and most amount of accidents.

<http://www.NHS.co.uk>

YEARLY INCIDENT STATISTICS

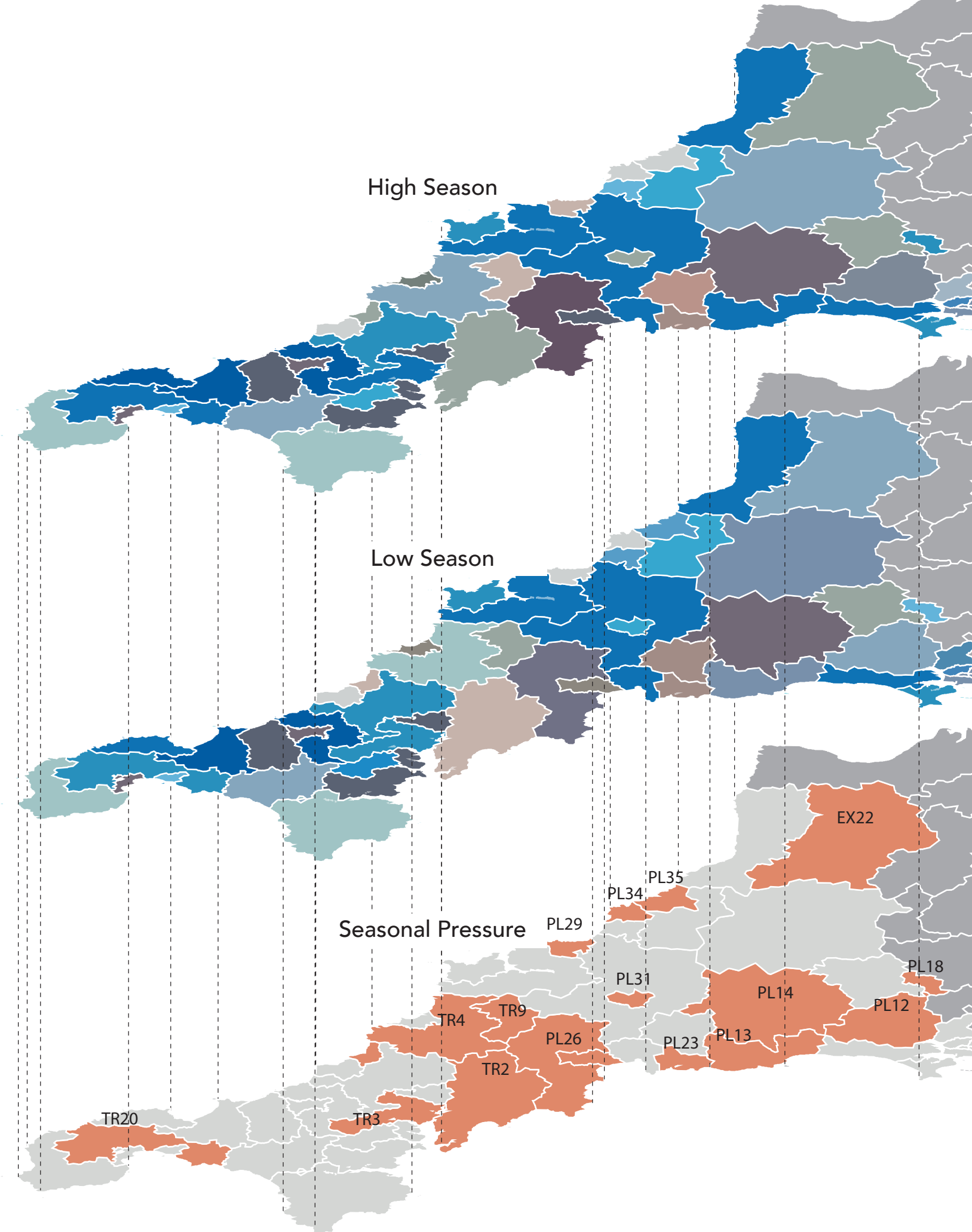
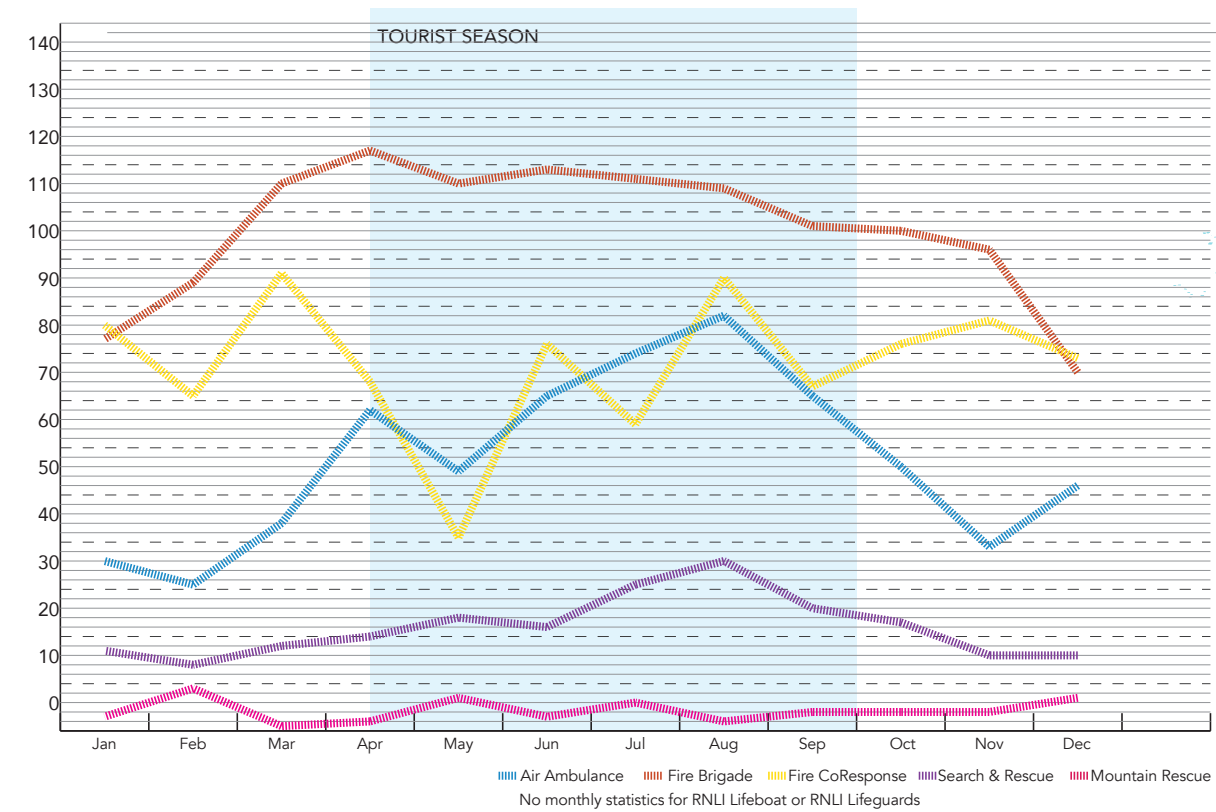

TOURIST RELATED PRESSURES

There are approximately 4.3m staying visitors and 14.7m day visitors to Cornwall each year. Using data from Visit Cornwall we have mapped out the locations that they stay. The size of the circles are proportionate to the amount of tourists.

Increased tourist population adds pressure to local health services and transport routes which also affects the ambulance service. The graph below shows that there is a peak in the volume of traffic on the three major roads during high season.

MAP KEY

- - Staying Visitor Trips
- - Day Trip Visitors

1mm Increase is the equivalent of 10,000

GRAPH SHOWING TRAFFIC FLOW IN 2016

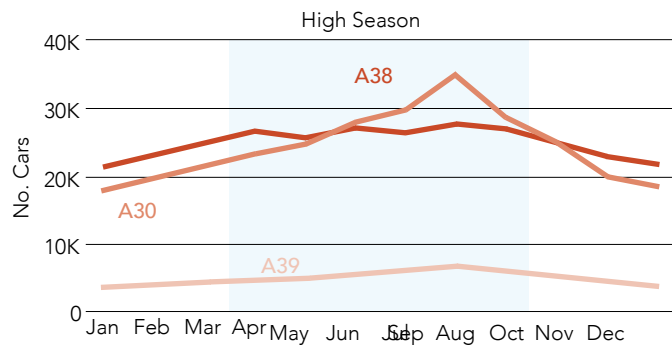

https://www.visitcornwall.com/sites/default/files/generic_files/CornwallTownsImpactofTourismResearc202012.pdf
<http://t-stats-uk.co.uk/Cornwall/Central/MonthYearTraffic>

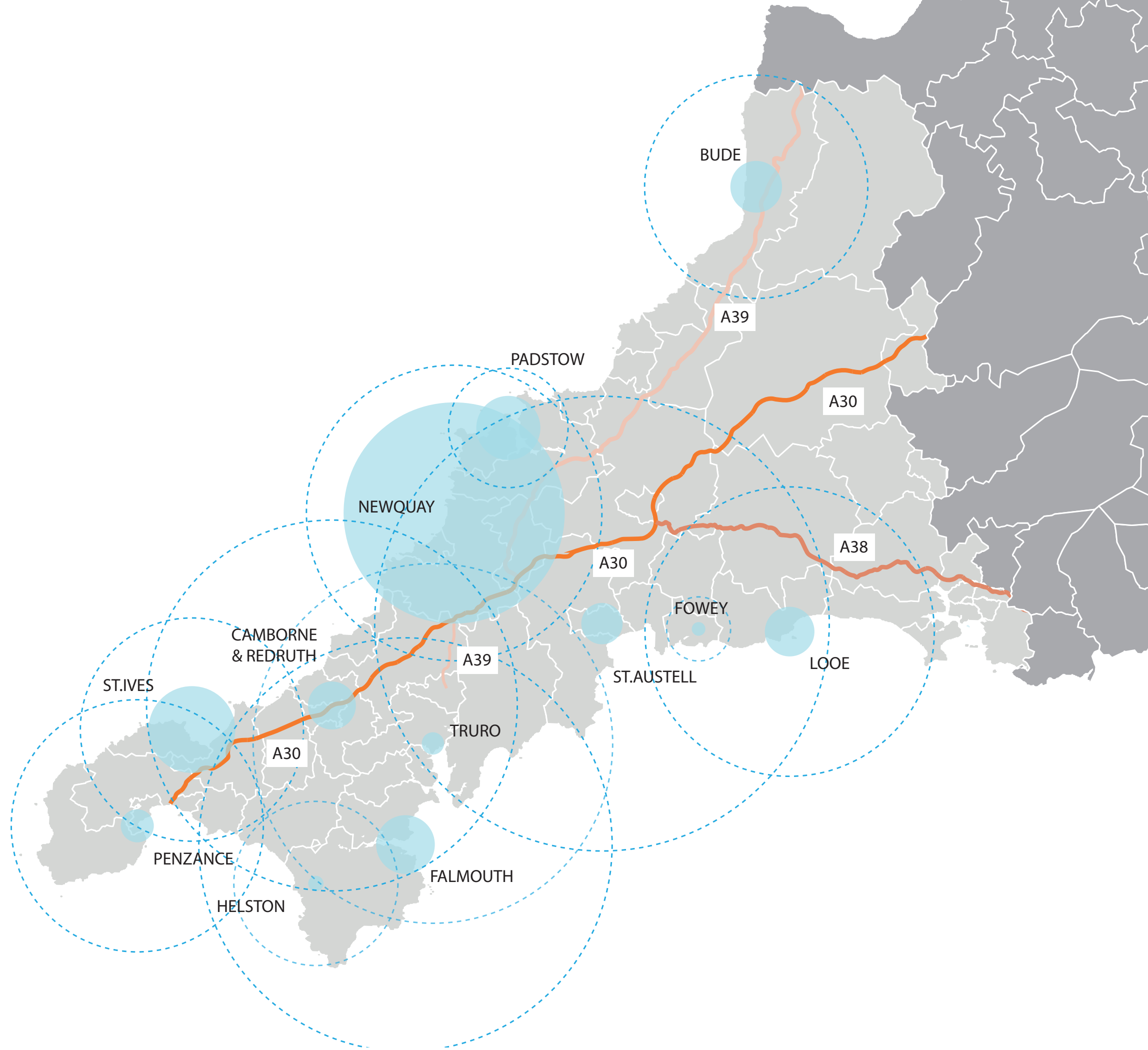

DIGITAL HEALTH CARE

Our findings suggest that connectivity is a significant issue in the provision and delivery of high quality health care in Cornwall. However, digital healthcare maybe one approach to tackle this.

Digital healthcare is a discipline specialising in the digitalisation of medical services through hardware and software. There are many different applications for digital health like the digitalisation of patients records which are already being used around the world.

In order to integrate digital healthcare successfully, its benefits and limitations for Cornwall must first be investigated and understood.

DIGITAL HEALTH IN CARE HOMES

Our research into care homes has lead to the understanding that there is a level of disconnect within the entire system which reduces the overall efficiency of the system.

TELE-HEALTHCARE IN EMERGENCIES

There is already a level of digital health care integrated through public defibrillators in Cornwall. This resource could be improved with the use of smart phones in order that patients can be contacted remotely before an ambulance or first responder arrives.

TELE-HEALTHCARE FOR LONG TERM HEALTH

One of the priorities for the NHS is the provision of assisted home care: tele-healthcare could be used to remotely monitor patients which in turn would reduce pressure on the system.

<http://www.entrepreneurcountryglobal.com/zoo/item/the-digital-healthcare-industry-a-prognosis>

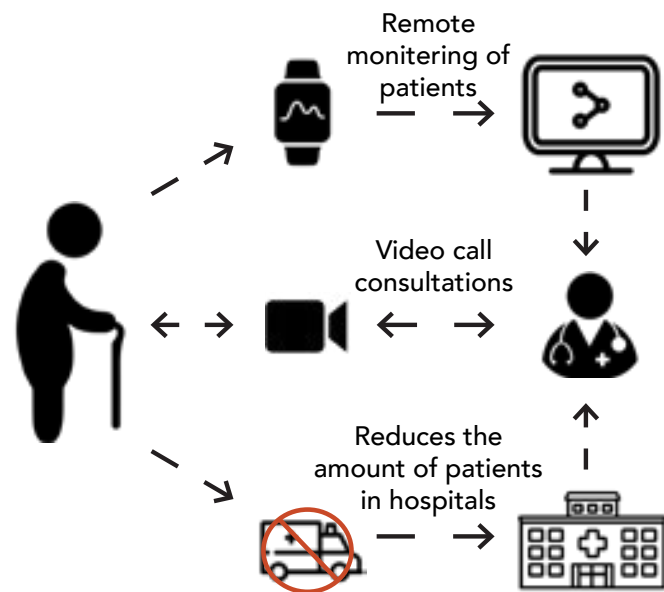

Linear Response

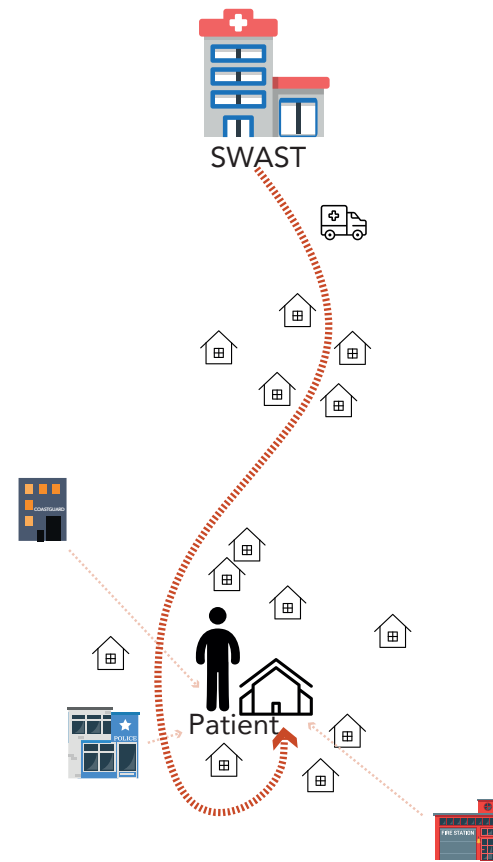

Co-Response

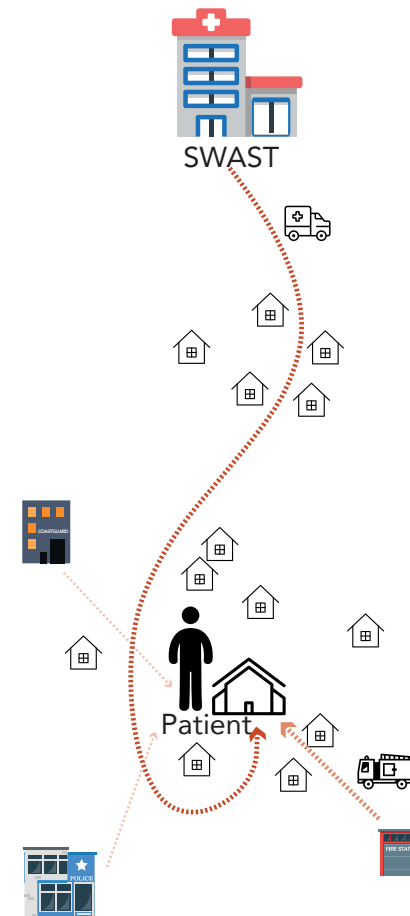

INTEGRATED EMERGENCY SERVICES

In the last decade there has been a 46% reduction in call outs and incidents. Deaths from fires in the home are now at an all time low. For this reason fire service across the country have looked at how to best use this underutilised resource. Since 1999, Cornwall Fire and Rescue Service has provided a co-responder service to the community on the Lizard Peninsula. These fire service personnel attend on average 25 life-threatening and non-emergency calls per year, and are raising the

profile of the fire and rescue service in rural areas. A faster response to medical emergencies by fire-fighters, with enhanced medical training, is a clear demonstration of an effective partnership with the ambulance trust. More recently Andrew Hitchens, based in Hayle, became the UK's first Tri-Service Safety officer which sees him able to respond as an on-call fire fighter, an emergency first responder and a PCSO19.

Quad- Emergency Service Coverage

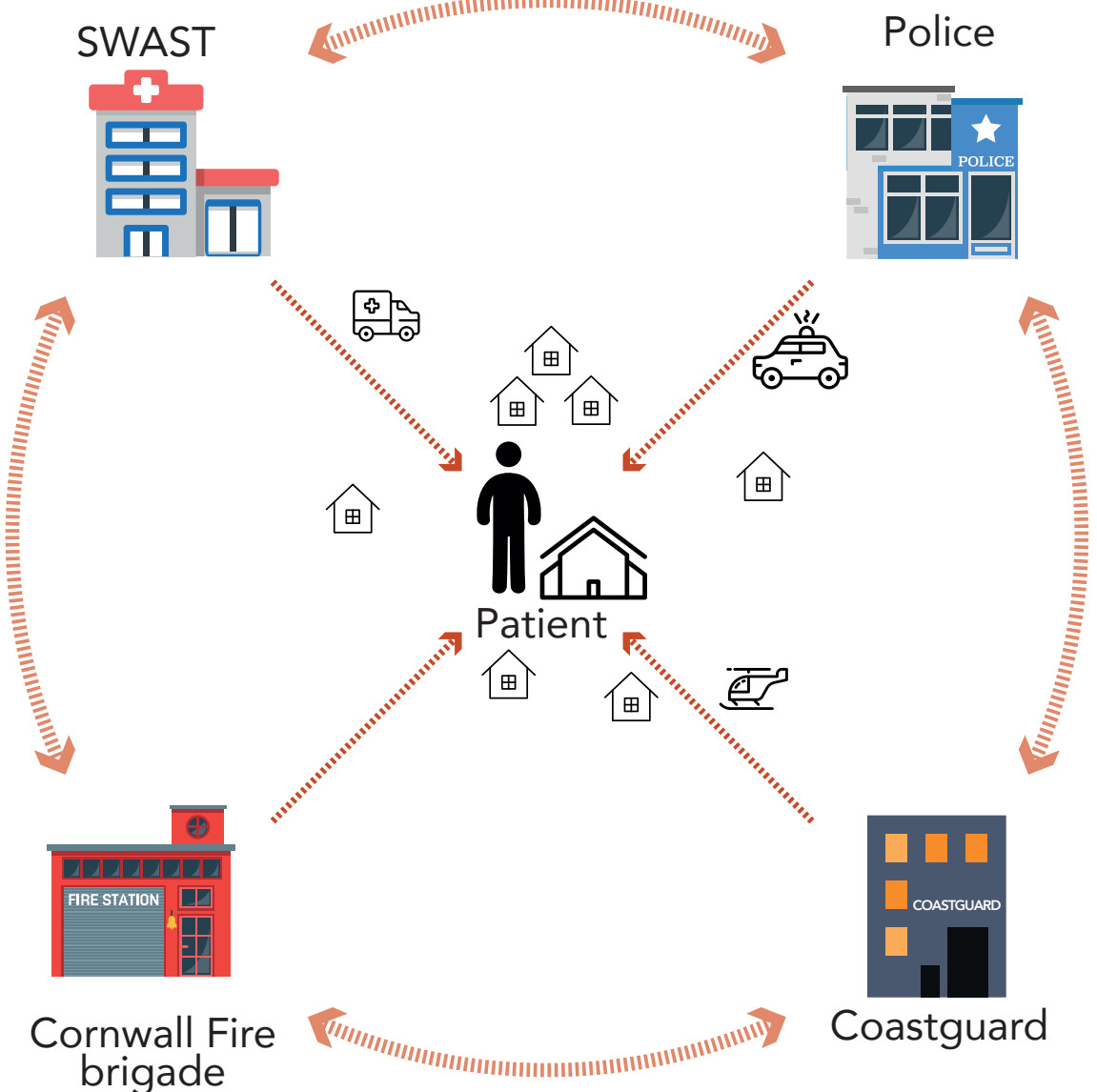

PRICE : £25.00

Published by
Manchester School
of Architecture

ISBN 978-0-9929673-3-8